

SECTION III

COMPONENT SECTION III	PAGE
Component Selection	51
Conveyor Screws	53
Coupling Bolts, Internal Collars and Lugs	63
Shafts	64
Hangers	68
Hanger Bearings	76
Trough Ends	78
Seals	85
End Bearings	88
Thrust Bearings	90
Trough	92
Saddles and Feet/Trough End Flanges	96
Discharges and Gates	97
Covers	103
Cover Accessories	105
Shrouds	106

**SEE PRICE LIST FOR ITEMS CARRIED
IN STOCK**

Required Information

- Screw diameter
- Shaft diameter
- Material component group
- Unusual material characteristics

Conveyor Screws

Standard length conveyor screws should be used whenever possible to reduce the number of hanger bearings required.

The recommended screws listed in the Component Series Table are standard helicoid and sectional screw conveyors. The use of helicoid or sectional conveyors is largely a matter of individual preference.

Right hand screw conveyors pull material toward the end which is being rotated in a clockwise direction. If the rotation is reversed (counterclockwise), the material is pushed away from that end.

In left hand screw conveyors, the material flow is opposite to that of right hand screws, the direction of rotation being unchanged.

To determine hand of screw see pages 39 and 40.

The material is carried on one face of the conveyor flighting in conveyors which are required to transport material in one direction, therefore, conveyor end lugs are located on the opposite face to facilitate unimpeded flow of the material. Conveyor sections must be installed in such a manner that all end lugs are toward the inlet end of the conveyor. Conveyor sections must not be turned end for end without reversing the direction of rotation, or conversely, the direction of rotation must not be reversed without turning the conveyor sections end for end.

Requirements for reversible conveyor screws intended for material transport in either direction should be referred to our Engineering Department.

Flighting should be omitted from the conveyor pipe over the last discharge opening to ensure complete discharge of material without carryover.

Continuity of material flow at hanger points is accomplished by opposing adjacent flight ends approximately 180°. (As close to 180° as the predrilled holes will allow.)

Conveyor Trough and Tubular Housing

Standard trough and housing sections are available in five, six, ten, and 12 foot lengths. Standard five and six foot lengths should be used when connecting flanges coincide with discharge openings or hanger bearings.

Shafts

The primary consideration in determining the type and size of coupling and drive shafts is whether the shafts selected are adequate to transmit the horsepower required, including any overload. Normally, cold-rolled shafts are adequate. However, high-tensile shafts may be required due to torque limitations. Also, stainless steel shafts may be necessary when corrosive or contaminable materials are to be handled. Conveyors equipped with non-lubricated hard iron hanger bearings require hardened coupling shafts. Specific shaft size determination is covered in the Torsional Rating Section, page 28.

Shaft Seals

Several conveyor end seal types are available to prevent contamination of the conveyed material or to prevent the escape of material from the system.

Bearings

Hanger Bearing — The purpose of hanger bearings is to provide intermediate support when multiple screw sections are used. Hanger bearings are designed primarily for radial loads. Therefore, adequate clearance should be allowed between the bearings and the conveyor pipe ends to prevent damage by the thrust load which is transmitted through the conveyor pipe.

The hanger bearing recommendations listed in the Material Characteristic Tables are generally adequate for the material to be handled. Often, however, unusual characteristics of the material or the conditions under which the conveyor must operate make it desirable to use special bearing materials. Regarding the use of special bearing materials, consult our Engineering Department.

End Bearings — Several end bearing types are available, and their selection depends on two basic factors: Radial load and thrust load. The relative values of these loads determines end bearing types.

Radial load is negligible at the conveyor tail shaft. However, drive ends (unless integrated with the conveyor end plate) are subject to radial loading due to overhung drive loads, such as chain sprockets or shaft-mounted speed reducers. Screw Conveyor Drive Reducers at the drive end will adequately carry both thrust and radial loads.

Discharge Spouts and Gates

Standard discharge spouts and gates are available for either conveyor trough or tubular housing in several designs, operated either manually or by remote controls.

In installations where it is possible to overfill the device to which material is being transported, an additional overflow discharge opening or overflow relief device should be provided. Consult our Engineering Department for suggested electrical interlock and safety devices to prevent overflow or damage to equipment.

It is sometimes found that the material characteristics are such that standard component specifications are inadequate. Should unusual material characteristics or severe conditions exist, our Engineering Department should be consulted.

Conveyor Ends

A complete line of conveyor ends are available as standard for either conveyor trough or tubular housing with a choice of many bearing types and combinations.

Special Applications

More common of the unusual material characteristics which require other than the recommended components are:

Corrosive Materials — Components may be fabricated from alloys not affected by the material or may be coated with a protective substance.

Contaminable Materials — Require the use of oil impregnated, sealed, or dry type hanger bearings. End shafts should be sealed to prevent entrance of contaminants from the outside. Due to the necessity for frequent cleaning conveyor components should be designed for convenient disassembly.

Abrasive Materials — These materials may be handled in conveyors, troughs, or housings constructed of abrasion resistant alloys with hard surfaced screws. Lining of all exposed surfaces with rubber or special resins also materially reduces abrasive damage.

Interlocking or Matting Materials — Conveying with standard components is sometimes possible by the use of special feeding devices at the conveyor inlet.

Hygroscopic Materials — Frequently these materials may be handled successfully in a conveyor which is substantially sealed from the exterior atmosphere. In extreme cases it is necessary to provide jacketed trough or housing with an appropriate circulating medium to maintain the material at an elevated temperature. Purging of the conveyor with a suitable dry gas is also used in some installations.

Viscous or Sticky Materials — Ribbon flight conveyor screws are most frequently used for conveying these materials although standard components may be specially coated to improve the flow of material.

Harmful Vapors or Dusts — These materials may be safely handled in dust sealed trough, plain tubular housing, or gasketed flanged tubular housing with particular attention to shaft sealing. Trough or housing exhaust systems have also been successfully used in some installations.

Blending in Transit — Ribbon, cut flight, paddle, or a combination of these screw types may be designed to produce the desired degree of blending, aeration or mixing.

Explosive Dusts — The danger of this condition may be minimized in most installations by the use of components which are fabricated from non-ferrous materials and proper conveyor sealing techniques observed. Exhaust systems are also advisable for the removal of explosive dusts.

Materials Subject to Packing — This condition requires the use of aerating devices at the conveyor inlet when materials are pulverulent and a special feeder device when material particles are large or fibrous.

Materials which are Fluid when Aerated — This condition may be used to advantage in some installations by declining the conveyor system toward the discharge end.

Degradable Materials — Some particles that are easily broken or distorted may usually be handled in screw conveyors by reducing the speed and selecting a larger conveyor size sufficient to deliver the required volume of material.

Elevated Temperature — Components should be fabricated from high temperature alloys. Should the process be such that cooling of the material in the conveyor is permissible, jacketed trough or housing may be used at the inlet end to cool the material and standard components used after the point where material temperature has been reduced to a safe degree.

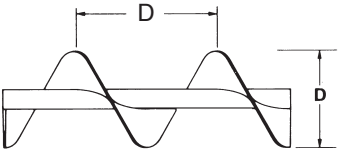
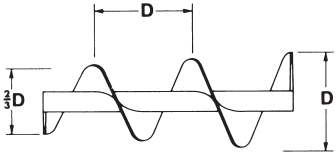
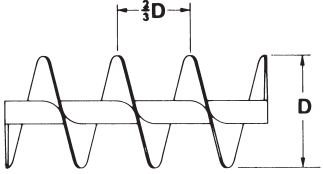
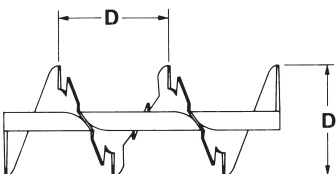
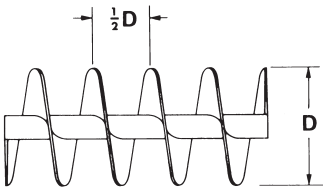
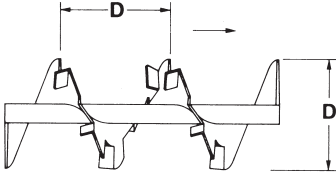
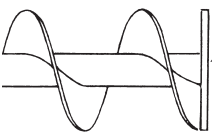
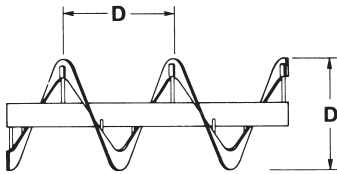
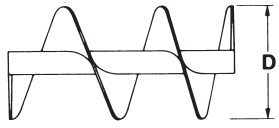
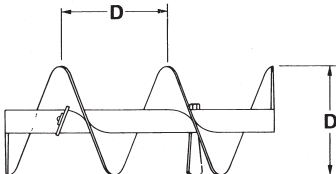
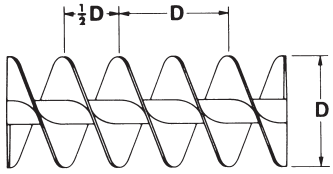
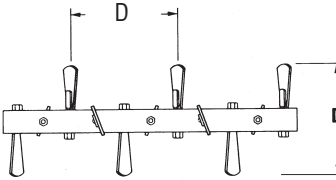
<p>STANDARD PITCH, SINGLE FLIGHT</p>  <p>Conveyor screws with pitch equal to screw diameter are considered standard. They are suitable for a whole range of materials in most conventional applications.</p>	<p>TAPERED, STANDARD PITCH, SINGLE</p>  <p>Screw flights increase from 2/3 to full diameter. Used in screw feeders to provide uniform withdrawal of lumpy materials. Generally equivalent to and more economical than variable pitch.</p> <p>Price on Application</p>
<p>SHORT PITCH, SINGLE FLIGHT</p>  <p>Flight pitch is reduced to 2/3 diameter. Recommended for inclined or vertical applications. Used in screw feeders. Shorter pitch reduces flushing of materials which fluidize.</p>	<p>SINGLE CUT-FLIGHT, STANDARD PITCH</p>  <p>Screws are notched at regular intervals at outer edge. Affords mixing action and agitation of material in transit. Useful for moving materials which tend to pack.</p>
<p>HALF PITCH, SINGLE FLIGHT</p>  <p>Similar to short pitch except pitch is reduced to 1/2 standard pitch. Useful for inclined applications, for screw feeders and for handling extremely fluid materials.</p>	<p>CUT & FOLDED FLIGHT, STANDARD PITCH</p>  <p>Folded flight segments lift and spill the material. Partially retarded flow provides thorough mixing action. Excellent for heating, cooling or aerating light substances.</p>
<p>END DISC ON CONVEYOR SCREW</p>  <p>An end disc is the same diameter as the screw and is welded flush with the end of the pipe shaft and, of course, rotates with the screw. The end disc helps to keep material away from the trough seal.</p> <p>Price on Application</p>	<p>SINGLE FLIGHT RIBBON</p>  <p>Excellent for conveying sticky or viscous materials. Open space between flighting and pipe eliminate collection and build-up of material.</p> <p>Price on Application</p>
<p>VARIABLE PITCH, SINGLE FLIGHT</p>  <p>Flights have increasing pitch and are used in screw feeders to provide uniform withdrawal of fine, free flowing materials over the full length of the inlet opening.</p> <p>Price on Application</p>	<p>STANDARD PITCH WITH PADDLES</p>  <p>Adjustable paddles positioned between screw flights opposed flow to provide gentle but thorough mixing action.</p>
<p>DOUBLE FLIGHT, STANDARD PITCH</p>  <p>Double flight, standard pitch screws provide smooth regular material flow and uniform movement of certain types or materials.</p>	<p>PADDLE</p>  <p>Adjustable paddles provide complete mixing action, and controlled material flow.</p>

Note: Other special screw types also available. Consult factory for details.

Helicoid Screw Conveyors

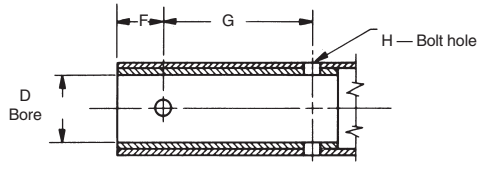
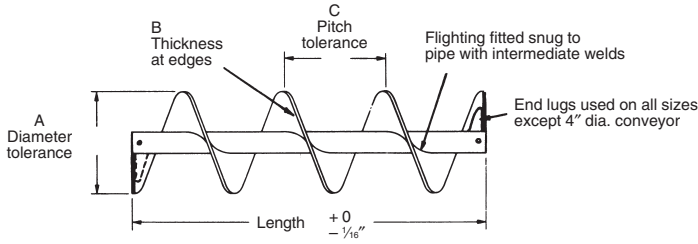

Listed Screw Diameter and Pitch	Coupling Diameter	Size Designation	Pipe Size Schedule 40	Length Feet and Inches	A		B		C		D		F	G	H
					Diameter Tolerance		Thickness		Pitch Tolerance		Bushing Bore Inside Diameter		Spacing 1st Bolt Hole	Centers 2nd Bolt Hole	Nominal Bolt Hole Size
					Plus	Minus	Inner Edge	Outer Edge	Plus	Minus	Minimum	Maximum			
4	1	4H206	1 1/4	9-10 1/2	1/16	1/8	3/16	3/32	1/2	1/4	1.005	1.016	1/2	2	1 3/32
6	1 1/2	6H304	2	9-10	1/16	3/16	1/8	1/16	1/2	1/4	1.505	1.516	7/8	3	1 7/32
6	1 1/2	6H308	2	9-10	1/16	3/16	1/4	1/8	3/4	1/4	1.505	1.516	7/8	3	1 7/32
6	1 1/2	6H312	2	9-10	1/16	3/16	3/8	3/16	3/4	1/4	1.505	1.516	7/8	3	1 7/32
9	1 1/2	9H306	2	9-10	1/16	3/16	3/16	3/32	3/4	1/4	1.505	1.516	7/8	3	1 7/32
9	1 1/2	9H312	2	9-10	1/16	3/16	3/8	3/16	3/4	1/4	1.505	1.516	7/8	3	1 7/32
9	2	9H406	2 1/2	9-10	1/16	3/16	3/16	3/32	3/4	1/4	2.005	2.016	7/8	3	2 1/32
9	2	9H412	2 1/2	9-10	1/16	1/4	3/8	3/16	3/4	1/4	2.005	2.016	7/8	3	2 1/32
9	2	9H414	2 1/2	9-10	1/16	1/4	7/16	7/32	3/4	1/4	2.005	2.016	7/8	3	2 1/32
10	1 1/2	10H306	2	9-10	1/16	3/16	3/16	3/32	3/4	1/4	1.505	1.516	7/8	3	1 7/32
10	2	10H412	2 1/2	9-10	1/16	1/4	3/8	3/16	3/4	1/4	2.005	2.016	7/8	3	2 1/32
12	2	12H408	2 1/2	11-10	1/8	5/16	1/4	1/8	1	1/4	2.005	2.016	7/8	3	2 1/32
12	2	12H412	2 1/2	11-10	1/8	5/16	3/8	3/16	1	1/4	2.005	2.016	7/8	3	2 1/32
12	2 1/16	12H508	3	11-9	1/8	5/16	1/4	1/8	1	1/4	2.443	2.458	1 5/16	3	2 1/32
12	2 1/16	12H512	3	11-9	1/8	5/16	3/8	3/16	1	1/4	2.443	2.458	1 5/16	3	2 1/32
12	3	12H614	3 1/2	11-9	1/8	3/8	7/16	7/32	1	1/4	3.005	3.025	1	3	2 5/32
14	2 1/16	14H508	3	11-9	1/8	5/16	1/4	1/8	1	1/4	2.443	2.458	1 5/16	3	2 1/32
14	3	14H614	3 1/2	11-9	1/8	3/8	7/16	7/32	1	1/4	3.005	3.025	1	3	2 5/32
16	3	16H610	3 1/2	11-9	1/8	3/8	5/16	3/32	1 1/2	1/4	3.005	3.025	1	3	2 5/32
16	3	16H614	4	11-9	1/8	3/8	7/16	7/32	1 1/2	1/4	3.005	3.025	1	3	2 5/32

NOTE: All dimensions in inches.

Cut Flight/Cut & Folded Flight Conveyors

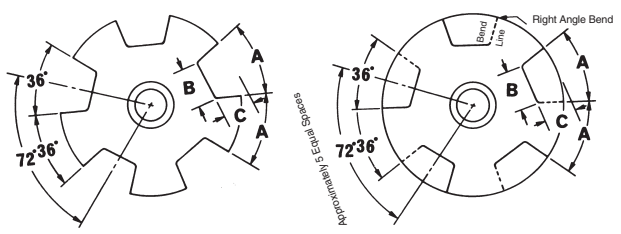

Depth of cut "C" is one half the flight width for normal maximum pipe size. Lengths "A" and "B" are calculated from the developed O.D. for standard pitch.

Screw Diameter	A	B	C
4	1 3/8	1	5/8
6	2	1 1/2	7/8
9	3	2 1/2	1 1/2
10	3 3/8	2 1/4	1 3/4
12	4	2 3/4	2
14	4 5/8	3 1/8	2 1/2
16	5 1/4	3 1/2	3
18	6	3 5/8	3 3/8
20	6 5/8	4 1/4	3 3/8
24	7 5/8	4 5/8	4 1/8

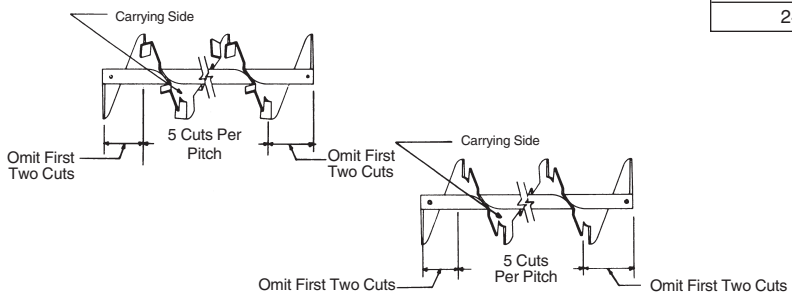

Sectional Screw Conveyors

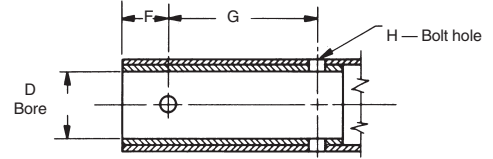
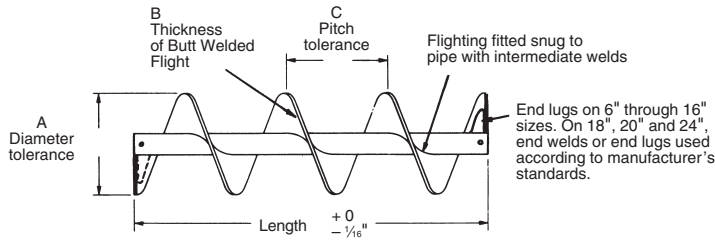

Listed Screw Diameter and Pitch	Cplng. Dia.	Size Designation	Pipe Size Schedule 40	Length Feet and Inches	A		B	C		D		F	G	H
					Diameter Tolerance			Pitch Tolerance	Bushing Bore Inside Diameter					
					Plus	Minus	Plus		Minus	Minimum	Maximum	Spacing 1st Bolt Hole	Centers 2nd Bolt Hole	Nominal Bolt Hole Size
6	1½	6S312	2	9-10	1/16	3/16	3/16	3/8	1/4	1.505	1.516	7/8	3	17/32
	1½	9S312	2	9-10	1/16	3/16	3/16	1/2	1/4	1.505	1.516	7/8	3	17/32
9	2	9S412	2½	9-10	1/16	3/16	3/16	1/2	1/4	2.005	2.016	7/8	3	21/32
	2	9S416	2½	9-10	1/16	1/4	1/4	1/2	1/4	2.005	2.016	7/8	3	21/32
10	2	10S412	2½	9-10	1/16	3/16	3/16	1/2	1/4	2.005	2.016	7/8	3	21/32
12	2	12S412	2½	11-10	1/8	5/16	3/16	3/4	1/4	2.005	2.016	7/8	3	21/32
	2 7/16	12S512	3	11-9	1/8	5/16	3/16	3/4	1/4	2.443	2.458	15/16	3	21/32
	2 7/16	12S516	3	11-9	1/8	5/16	1/4	3/4	1/4	2.443	2.458	15/16	3	21/32
	3	12S616	3½	11-9	1/8	5/16	1/4	3/4	1/4	3.005	3.025	1	3	25/32
14	3	12S624	3½	11-9	1/8	3/8	3/8	3/4	1/4	3.005	3.025	1	3	25/32
	2 7/16	14S512	3	11-9	1/8	5/16	3/16	3/4	1/4	2.443	2.458	15/16	3	21/32
	3	14S616	3½	11-9	1/8	5/16	1/4	3/4	1/4	3.005	3.025	1	3	25/32
16	3	14S624	3½	11-9	1/8	3/8	3/8	3/4	1/4	3.005	3.025	1	3	25/32
	3	16S612	3½	11-9	1/8	3/8	3/16	3/4	1/4	3.005	3.025	1	3	25/32
	3	16S616	3½	11-9	1/8	3/8	1/4	3/4	1/4	3.005	3.025	1	3	25/32
	3	16S624	3½	11-9	1/8	3/8	3/8	3/4	1/4	3.005	3.025	1	3	25/32
18	3	16S632	3½	11-9	1/8	1/2	1/2	3/4	1/4	3.005	3.025	1	3	25/32
	3	18S612	3½	11-9	3/16	3/8	3/16	3/4	1/2	3.005	3.025	1	3	25/32
	3	18S616	3½	11-9	3/16	3/8	1/4	3/4	1/2	3.005	3.025	1	3	25/32
	3	18S624	3½	11-9	3/16	3/8	3/8	3/4	1/2	3.005	3.025	1	3	25/32
20	3	18S632	3½	11-9	3/16	1/2	1/2	3/4	1/2	3.005	3.025	1	3	25/32
	3	20S612	3½	11-9	3/16	3/8	3/16	7/8	1/2	3.005	3.025	1	3	25/32
	3	20S616	3½	11-9	3/16	3/8	1/4	7/8	1/2	3.005	3.025	1	3	25/32
	3	20S624	3½	11-9	3/16	3/8	3/8	7/8	1/2	3.005	3.025	1	3	25/32
24	3 7/16	24S712	4	11-8	3/16	3/8	3/16	7/8	1/2	3.443	3.467	1½	4	29/32
	3 7/16	24S716	4	11-8	3/16	3/8	1/4	7/8	1/2	3.443	3.467	1½	4	29/32
	3 7/16	24S724	4	11-8	3/16	3/8	3/8	7/8	1/2	3.443	3.467	1½	4	29/32
	3 7/16	24S732	4	11-8	3/16	1/2	1/2	7/8	1/2	3.443	3.467	1½	4	29/32

NOTE: All dimensions in inches.

Helicoid flights are formed in a special rolling machine by forming a steel strip into a continuous one-piece helix of the desired diameter, pitch and thickness to fit conveyor screw pipes. The helicoid flight is tapered in cross section, with the thickness at the inner edge approximately twice the thickness of the outer edge.

Sectional flights are individual flights or turns blanked from steel plates and formed into a spiral or helix of the desired diameter and pitch to fit conveyor screw pipes. The flights are butt welded together to form a continuous conveyor screw. Modifications can be furnished, such as, fabrication from various metals, different flight thicknesses, other diameters and pitches. The butt weld flight is the same thickness in the full cross section.



Helicoid Flight



Sectional Flight

Key to Conveyor Size Designation

The letter "H" indicates screw conveyor with helicoid flighting. The figures to the left of the letters indicate the nominal outside diameter of the conveyor in inches. The first figure following the letters is twice the diameter of the couplings in inches. The last two figures indicate the nominal thickness of flighting at the outer edge in $\frac{1}{64}$ ". Thus conveyor 12H408 indicates 12" diameter helicoid conveyor for 2" couplings with flighting $\frac{3}{64}$ " or $\frac{1}{8}$ " thickness at outer edge. Hand of conveyor is indicated by "R" or "L" following the designation.

Comparison Table • helicoid flight and sectional flight conveyor screws

Screw Diameter, Inches	Helicoid Flight						Sectional Flight			
	Conveyor Screw Size Designation ▲	Former Designation	Coupling Diameter, Inches	Nominal Inside Diameter of Pipe, Inches	Thickness of Flight, Inches		Conveyor Screw Size Designation ▲	Coupling Diameter, Inches	Nominal Inside Diameter of Pipe, Inches	Thickness of Flight
					Inner Edge	Outer Edge				
4	4H206	4X	1	1¼	$\frac{3}{16}$	$\frac{3}{32}$				
6	6H304	6 Standard	1½	2	$\frac{1}{8}$	$\frac{1}{16}$	6S309 6S312	1½	2	10 ga. $\frac{3}{16}$ in.
	6H308	6 X	1½	2	$\frac{1}{4}$	$\frac{1}{8}$				
	6H312	6 XX	1½	2	$\frac{3}{8}$	$\frac{3}{16}$				
9	9H306	9 Standard	1½	2	$\frac{3}{16}$	$\frac{3}{32}$	9S307 9S407 9S312 9S412 9S416	1½	2	12 ga. 12 ga. $\frac{3}{16}$ in. $\frac{3}{16}$ in. $\frac{1}{4}$ in.
	9H406	9 Special	2	2½	$\frac{3}{16}$	$\frac{3}{32}$				
	9H312	9 X	1½	2	$\frac{3}{8}$	$\frac{3}{16}$				
	9H412	9 XX	2	2½	$\frac{3}{8}$	$\frac{3}{16}$				
	9H414	—	2	2½	$\frac{7}{16}$	$\frac{7}{32}$				
10	10H306	10 Standard	1½	2	$\frac{3}{16}$	$\frac{3}{32}$	10S309 10S412	1½	2	10 ga. $\frac{3}{16}$ in.
	10H412	10 XX	2	2½	$\frac{3}{8}$	$\frac{3}{16}$				
12	12H408	12 Standard	2	2½	$\frac{1}{4}$	$\frac{1}{8}$	12S409 12S509 12S412 12S512 12S616	2	2½	10 ga. 10 ga. $\frac{3}{16}$ in. $\frac{3}{16}$ in. $\frac{1}{4}$ in.
	12H508	12 Special	2 $\frac{7}{16}$	3	$\frac{1}{4}$	$\frac{1}{8}$				
	12H412	12 X	2	2½	$\frac{3}{8}$	$\frac{3}{16}$				
	12H512	12 XX	2 $\frac{7}{16}$	3	$\frac{3}{8}$	$\frac{3}{16}$				
	12H614	—	3	3½	$\frac{7}{16}$	$\frac{7}{32}$				
14	14H508	14 Standard	2 $\frac{7}{16}$	3	$\frac{1}{4}$	$\frac{1}{8}$	14S509 14S616	2 $\frac{7}{16}$	3	10 ga. $\frac{1}{4}$ in.
	14H614	14 XX	3	3½	$\frac{7}{16}$	$\frac{7}{32}$				
16	16H610	16 Standard	3	3½	$\frac{3}{16}$	$\frac{3}{32}$	16S609 16S616	3	3½	10 ga. $\frac{1}{4}$ in.
	16H614	—	3	4	$\frac{7}{16}$	$\frac{7}{32}$				

▲ Size designation: Examples: 12H412 and 12S412.
 12 = screw diameter in inches
 H = helicoid flight
 S = sectional flight
 4 = 2 times 2" coupling diameter
 12 = thickness of flight at periphery in increments of $\frac{1}{64}$ "

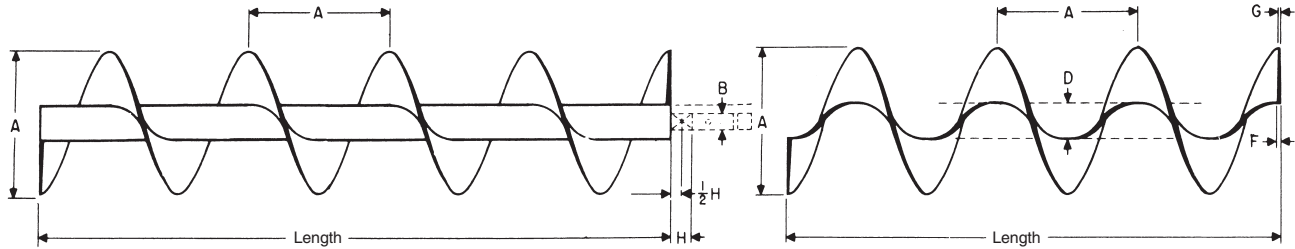

Helicoid Conveyor Screw

Flighting

Screw Diameter	Coupling Diameter	Size Part No. Conveyor Mounted	Size Part No. Flighting Only	D Pipe Size		Flight Thickness		H Coupling Bearing Length	Standard Length Feet-Inches	Average Weight			
						F Inside	G Outside			Complete Screw		Flighting Only	
				Inside	Outside					Standard Length	Per Foot	Standard Length	Per Foot
				4	1	4H206 ^{-*}	4HF206 ^{-*}	1¼	1½	⅜	⅜	1½	9-10½
6	1½	6H304 ^{-*}	6HF304 ^{-*}	2	2½	⅜	⅜	2	9-10	52	5	14	1.4
	1½	6H308 ^{-*}	6HF308 ^{-*}	2	2½	¼	⅜	2	9-10	62	6	28	2.8
	1½	6H312 ^{-*}	6HF312 ^{-*}	2	2½	⅜	⅜	2	9-10	72	7	42	4.3
9	1½	9H306 ^{-*}	9HF306 ^{-*}	2	2½	⅜	⅜	2	9-10	70	7	31	3.2
	1½	9H312 ^{-*}	9HF312 ^{-*}	2	2½	⅜	⅜	2	9-10	101	10	65	6.1
	2	9H406 ^{-*}	9HF406 ^{-*}	2½	2½	⅜	⅜	2	9-10	91	9	30	3.0
	2	9H412 ^{-*}	9HF412 ^{-*}	2½	2½	⅜	⅜	2	9-10	121	12	60	6.6
	2	9H414 ^{-*}	9HF414 ^{-*}	2½	2½	⅜	⅜	2	9-10	131	13	70	6.3
10	1½	10H306 ^{-*}	10HF306 ^{-*}	2	2½	⅜	⅜	2	9-10	81	8	48	4.9
	2	10H412 ^{-*}	10HF412 ^{-*}	2½	2½	⅜	⅜	2	9-10	130	13	76	7.7
12	2	12H408 ^{-*}	12HF408 ^{-*}	2½	2½	¼	⅜	2	11-10	140	12	67	5.7
	2	12H412 ^{-*}	12HF412 ^{-*}	2½	2½	⅜	⅜	2	11-10	180	15	102	8.6
	2½	12H508 ^{-*}	12HF508 ^{-*}	3	3½	¼	⅜	3	11-9	168	14	64	5.4
	2½	12H512 ^{-*}	12HF512 ^{-*}	3	3½	⅜	⅜	3	11-9	198	17	96	8.2
14	3	12H614 ^{-*}	12HF614 ^{-*}	3½	4	⅜	⅜	3	11-9	220	18	112	9.3
	2½	14H508 ^{-*}	14HF508 ^{-*}	3	3½	¼	⅜	3	11-9	170	14	84	7.1
16	3	14H614 ^{-*}	14HF614 ^{-*}	3½	4	⅜	⅜	3	11-9	254	22	132	11.2
	3	16H610 ^{-*}	16HF610 ^{-*}	3½	4	⅜	⅜	3	11-9	228	19	120	10.0
16	3	16H614 ^{-*}	16HF614 ^{-*}	4	4½	⅜	⅜	3	11-9	285	24	154	11.7
	3	18H610 ^{-*}	18HF610 ^{-*}	3½	4	⅜	⅜	3	11-9	282	24	167	13.9

^{-*} R For Right Hand
^{-*} L For Left Hand

▲ Offered only in full pitch helicoid flighting.

Conveyor Screws (Sectional)

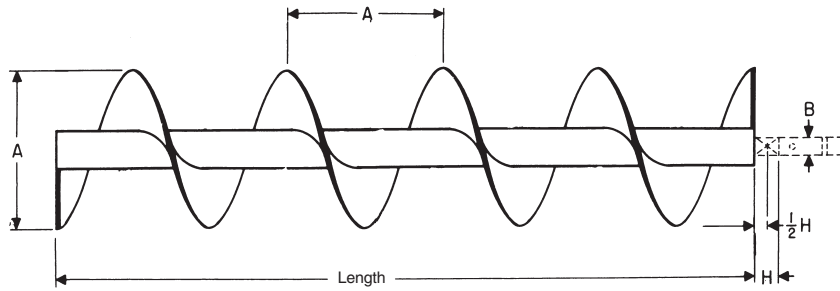

Sectional Conveyor Screw

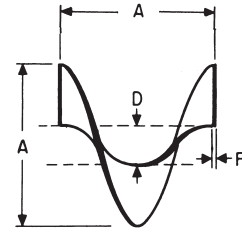

Flight

Screw Diameter	Coupling Diameter	Size Part No. Mounted Conveyor	Size Part No. Fighting Only	Pipe Size		F Flight Thickness	H Coupling Bearing Length	Standard Length Feet-Inches	Average Weight			Approx. Flights Per Foot
				Inside	D Outside				Standard Length	Per Foot	Flight Each	
6	1½	6S312-*	6SF312-*	2	2¾	⅜	2	9-10	75	7.5	1.7	2.0
	1½	6S316-*	6SF316-*	2	2¾	¼	2	9-10	90	8.0	2.2	2.0
9	1½	9S312-*	9SF312-*	2	2¾	⅜	2	9-10	95	9.5	4.3	1.33
	1½	9S316-*	9SF316-*	2	2¾	¼	2	9-10	130	13.0	5.5	1.33
	1½	9S324-*	9SF324-*	2	2¾	⅜	2	9-10	160	16.0	7.9	1.33
	2	9S412-*	9SF412-*	2½	2¾	⅜	2	9-10	115	11.5	4.3	1.33
	2	9S416-*	9SF416-*	2½	2¾	¼	2	9-10	130	13.0	5.5	1.33
	2	9S424-*	9SF424-*	2½	2¾	⅜	2	9-10	160	16.0	7.9	1.33
10	1½	10S312-*	10SF312-*	2	2¾	⅜	2	9-10	120	12.0	5.0	1.2
	1½	10S316-*	10SF316-*	2	2¾	¼	2	9-10	135	13.5	6.7	1.2
	1½	10S324-*	10SF324-*	2	2¾	⅜	2	9-10	165	16.5	8.7	1.2
	2	10S412-*	10SF412-*	2½	2¾	⅜	2	9-10	120	12.0	5.0	1.2
	2	10S416-*	10SF416-*	2½	2¾	¼	2	9-10	135	13.5	6.7	1.2
	2	10S424-*	10SF424-*	2½	2¾	⅜	2	9-10	165	16.5	8.7	1.2
12	2	12S412-*	12SF412-*	2½	2¾	⅜	2	11-10	156	13.0	7.2	1.0
	2	12S416-*	12SF416-*	2½	2¾	¼	2	11-10	204	17.0	9.7	1.0
	2	12S424-*	12SF424-*	2½	2¾	⅜	2	11-10	268	22.3	12.7	1.0
	2⅞	12S509-*	12SF509-*	3	3½	10 Ga.	3	11-9	160	14.0	5.7	1.0
	2⅞	12S512-*	12SF512-*	3	3½	⅜	3	11-9	178	14.8	7.2	1.0
	2⅞	12S516-*	12SF516-*	3	3½	¼	3	11-9	210	17.5	9.7	1.0
	2⅞	12S524-*	12SF524-*	3	3½	⅜	3	11-9	274	22.5	12.7	1.0
	3	12S612-*	12SF612-*	3½	4	⅜	3	11-9	198	16.5	7.2	1.0
	3	12S616-*	12SF616-*	3½	4	¼	3	11-9	216	18.0	9.7	1.0
	3	12S624-*	12SF624-*	3½	4	⅜	3	11-9	280	24.0	12.7	1.0

-* R For Right Hand
-* L For Left Hand

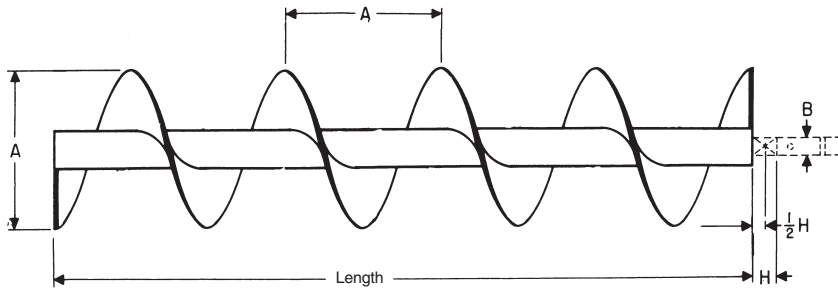

Sectional Conveyor Screw

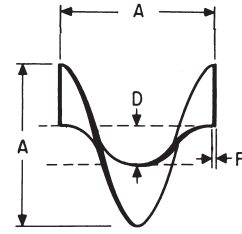

Flight

Screw Diameter	Coupling Diameter	Size Part No. Mounted Conveyor	Size Part No. Fighting Only	Pipe Size		F Flight Thickness	H Coupling Bearing Length	Standard Length Feet-Inches	Average Weight			Approx. Flights Per Foot
				Inside	D Outside				Standard Length	Per Foot	Flight Each	
14	2 ⁷ / ₁₆	14S512-*	14SF512-*	3	3 ¹ / ₂	3 ³ / ₁₆	3	11-9	214	18.0	9.9	.86
	2 ⁷ / ₁₆	14S516-*	14SF516-*	3	3 ¹ / ₂	1 ¹ / ₄	3	11-9	240	20.0	13.2	.86
	2 ⁷ / ₁₆	14S524-*	14SF524-*	3	3 ¹ / ₂	3 ³ / ₈	3	11-9	330	27.5	19.8	.86
	3	14S612-*	14SF612-*	3 ¹ / ₂	4	3 ³ / ₁₆	3	11-9	222	19.0	9.9	.86
16	3	14S616-*	14SF616-*	3 ¹ / ₂	4	1 ¹ / ₄	3	11-9	246	21.0	13.2	.86
	3	14S624-*	14SF624-*	3 ¹ / ₂	4	3 ³ / ₈	3	11-9	342	29.0	19.8	.86
	3	16S612-*	16SF612-*	3 ¹ / ₂	4	3 ³ / ₁₆	3	11-9	234	20.0	14.0	.75
	3	16S616-*	16SF616-*	3 ¹ / ₂	4	1 ¹ / ₄	3	11-9	282	24.0	18.0	.75
18	3	16S624-*	16SF624-*	3 ¹ / ₂	4	3 ³ / ₈	3	11-9	365	31.0	25.5	.75
	3	16S632-*	16SF632-*	3 ¹ / ₂	4	1 ¹ / ₂	3	11-9	402	33.5	36.0	.75
	3	18S612-*	18SF612-*	3 ¹ / ₂	4	3 ³ / ₁₆	3	11-9	246	21.0	18.0	.67
	3	18S616-*	18SF616-*	3 ¹ / ₂	4	1 ¹ / ₄	3	11-9	294	25.0	24.0	.67
	3	18S624-*	18SF624-*	3 ¹ / ₂	4	3 ³ / ₈	3	11-9	425	36.0	34.5	.67
	3	18S632-*	18SF632-*	3 ¹ / ₂	4	1 ¹ / ₂	3	11-9	530	44.0	46.0	.67
	3 ⁷ / ₁₆	18S712-*	18SF712-*	4	4 ¹ / ₂	3 ³ / ₁₆	4	11-8	293	24.4	18.0	.67
	3 ⁷ / ₁₆	18S716-*	18SF716-*	4	4 ¹ / ₂	1 ¹ / ₄	4	11-8	345	28.8	24.0	.67
20	3 ⁷ / ₁₆	18S724-*	18SF724-*	4	4 ¹ / ₂	3 ³ / ₈	4	11-8	470	39.2	34.5	.67
	3 ⁷ / ₁₆	18S732-*	18SF732-*	4	4 ¹ / ₂	1 ¹ / ₂	4	11-8	570	47.5	46.0	.67
	3	20S612-*	20SF612-*	3 ¹ / ₂	4	3 ³ / ₁₆	3	11-9	300	26.0	20.0	.60
	3	20S616-*	20SF616-*	3 ¹ / ₂	4	1 ¹ / ₄	3	11-9	360	31.0	28.0	.60
	3	20S624-*	20SF624-*	3 ¹ / ₂	4	3 ³ / ₈	3	11-9	410	33.4	40.0	.60
	3	20S632-*	20SF632-*	3 ¹ / ₂	4	1 ¹ / ₂	3	11-9	506	42.2	56.0	.60
	3 ⁷ / ₁₆	20S712-*	20SF712-*	4	4 ¹ / ₂	3 ³ / ₁₆	4	11-8	310	27.0	20.0	.60
	3 ⁷ / ₁₆	20S716-*	20SF716-*	4	4 ¹ / ₂	1 ¹ / ₄	4	11-8	370	32.0	28.0	.60
24	3 ⁷ / ₁₆	20S724-*	20SF724-*	4	4 ¹ / ₂	3 ³ / ₈	4	11-8	475	40.0	40.0	.60
	3 ⁷ / ₁₆	20S732-*	20SF732-*	4	4 ¹ / ₂	1 ¹ / ₂	4	11-8	525	45.0	56.0	.60
	3 ⁷ / ₁₆	24S712-*	24SF712-*	4	4 ¹ / ₂	3 ³ / ₁₆	4	11-8	440	37.0	32.0	.50
	3 ⁷ / ₁₆	24S716-*	24SF716-*	4	4 ¹ / ₂	1 ¹ / ₄	4	11-8	510	43.0	42.0	.50
24	3 ⁷ / ₁₆	24S724-*	24SF724-*	4	4 ¹ / ₂	3 ³ / ₈	4	11-8	595	50.0	63.0	.50
	3 ⁷ / ₁₆	24S732-*	24SF732-*	4	4 ¹ / ₂	1 ¹ / ₂	4	11-8	690	60.0	84.0	.50

-* R For Right Hand
-* L For Left Hand

Conveyor Screws (Ribbon)

Ribbon flight conveyor screws consist of sectional flights, butt-welded together to form a continuous helix. Flights are secured to the pipe by supporting legs. Both ends of the pipe are prepared with internal collars and drilling to accept couplings, drive shafts, and end shafts. They are used to convey sticky, gummy, or viscous substances, or where the material tends to adhere to flighting and pipe.

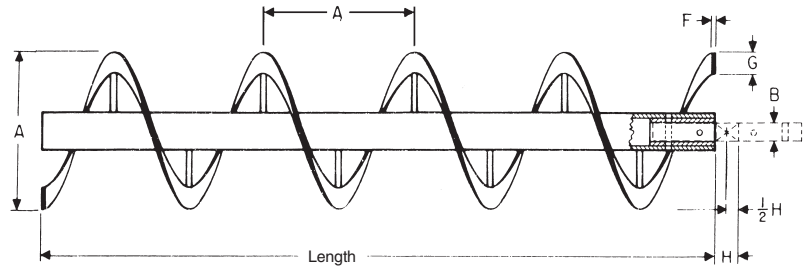

Ribbon Conveyor Screw

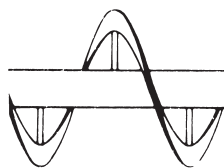

Post

**Integral (Int)
Leg**

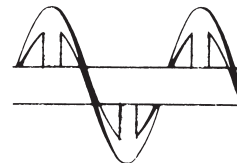

A Screw Diameter	B Coupling Diameter	Size Part No. Mounted Conveyor	Pipe Size		Flight Size		H Coupling Bearing Length	Standard Length Feet-Inches	Weight	
			Inside	Outside	F Thickness	G Width			Complete Screw	
									Standard Length	Per Foot
6	1½	6R312-*	2	2¾	⅜	1	2	9-10	65	6.5
9	1½	9R316-*	2	2¾	¼	1½	2	9-10	100	10
10	1½	10R316-*	2	2¾	¼	1½	2	9-10	110	11
12	2	12R416-*	2½	2¾	¼	2	2	11-10	180	15
	2	12R424-*	2½	2¾	⅜	2½	2	11-10	216	19
	2⅞	12R524-*	3	3½	⅜	2½	3	11-9	240	21
14	2⅞	14R516-*	3	3½	¼	2½	3	11-9	228	19
	2⅞	14R524-*	3	3½	⅜	2½	3	11-9	264	22
	3	14R624-*	3½	4	⅜	2½	3	11-9	288	25
16	3	16R616-*	3½	4	¼	2½	3	11-9	276	24
	3	16R624-*	3½	4	⅜	2½	3	11-9	324	28
18	3	18R624-*	3½	4	⅜	3	3	11-9	384	33
20	3⅞	20R724-*	4	4½	⅜	3	4	11-8	408	35
24	3⅞	24R724-*	4	4½	⅜	3	4	11-8	424	36

-* R For Right Hand
-* L For Left Hand

Quick Detachable (QD) Helicoid Conveyor

Q.D. — Quick Detachable conveyor screws are designed for convenient removal from the conveyor assembly. Each section of screw has a Q.D. cap at one end of the pipe. By removing this cap, a conveyor screw section can quickly and easily be removed and returned to the conveyor assembly without disturbing the other screw sections. Quick Detachable conveyor can be furnished both in helicoid and butt weld construction.

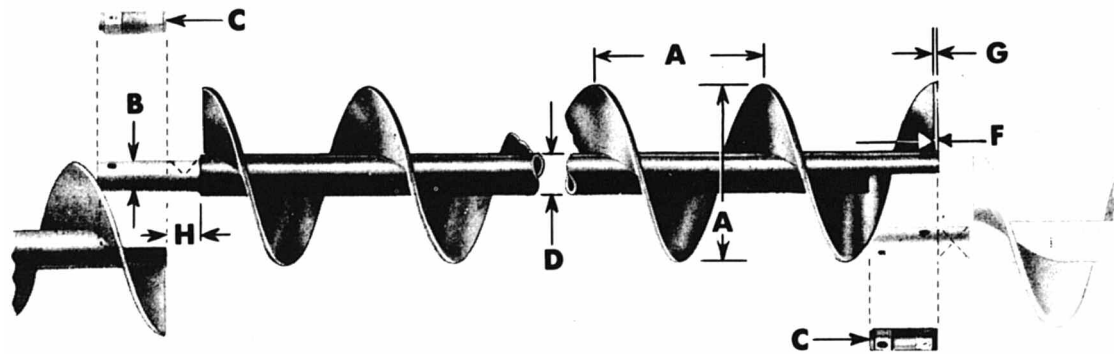

R.H. Shown

A Nominal Conveyor Diameter	Size Part No. Mounted Conveyor	B Coupling Diameter	Standard-Length Feet-Inches		C Cap Part Number	D Pipe Size		Flight Thickness		H Coupling Bearing Length	Average Weight	
			End to End of Pipe			Inside	Outside	F Inside	G Outside		Standard Length	Per Foot
6	6HQ304-*	1½	9'-10	3QDC2	2	2¾	⅛	⅙	2	52	5	
	6HQ308-*						¼	⅙		62	6	
	6HQ312-*						⅜	⅙		72	7	
9	9HQ306-*	1½	9'-10	3QDC2	2	2¾	⅜	⅜	2	70	7	
	9HQ312-*						⅝	⅜		101	10	
	9HQ406-*	2	9'-10	4QDC25	2½	2¾	⅜	⅜	2	91	9	
10	9HQ412-*	2	9'-10	4QDC25	2½	2¾	⅝	⅜	2	121	12	
	9HQ414-*						7/16	7/32		2	131	13
10	10HQ306-*	1½	9'-10	3QDC2	2	2¾	⅜	⅜	2	81	8	
	10HQ412-*						2	9'-10		4QDC25	2½	2¾
12	12HQ408-*	2	11'-10	4QDC25	2½	2¾	¼	⅙	2	140	12	
	12HQ412-*						⅜	⅜		2	180	15
	12HQ508-*	2⅙	11'-9	5QDC3	3	3½	¼	⅙	3	168	14	
12	12HQ512-*	3	11'-9	6QDC35	3½	4	⅝	⅜	3	198	17	
	12HQ614-*						7/16	7/32		3	220	18
	12HQ614-*						3	11'-9		6QDC35	3½	4
14	14HQ508-*	2⅙	11'-9	5QDC3	3	3½	¼	⅙	3	170	14	
	14HQ614-*						3	11'-9		6QDC35	3½	4
16	16HQ610-*	3	11'-9	6QDC35	3½	4	⅝	⅜	3	228	19	
	16HQ614-*						3	11'-9		6QDC4	4	4½
18	18HQ610-*	3	11'-9	6QDC35	3½	4	⅝	⅜	3	282	24	

Note: Q.D. caps are not recommended on the drive shaft end.
 -* R For Right Hand
 -* L For Left Hand

Quick Detachable (QD) Sectional Spiral Conveyors

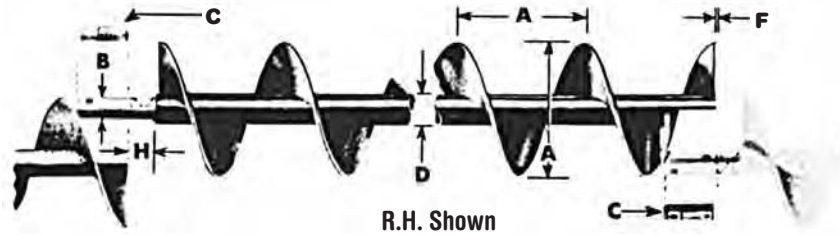

A Nominal Conveyor Diameter	Size Part No. Mounted Conveyor	B Coupling Diameter	Standard Length Feet-Inches End to End of Pipe	C Cap Part Number	D Pipe Size		F Flight Thickness	H Coupling Bearing Length	Average Weight	
					Inside	Outside			Standard Length	Per Foot
6	6SQ307-*	1½	9'-10	3QDC2	2	2¾	12	2	62	6.2
	6SQ309-*								65	6.5
	6SQ312-*								75	7.5
	6SQ316-*								90	8.0
9	9SQ307-*	1½	9'-10	3QDC2	2	2¾	12	2	73	7.3
	9SQ309-*								80	8.0
	9SQ312-*								95	9.5
	9SQ316-*								120	13
	9SQ407-*	2	9'-10	4QDC25	2½	2¾	12	2	90	9
	9SQ409-*								100	10
	9SQ412-*								115	11.5
	9SQ416-*								130	13.0
	9SQ424-*								160	16
10	10SQ309-*	1½	9'-10	3QDC2	2	2¾	10	2	85	8.5
	10SQ412-*	2	9'-10	4QDC25	2½	2¾	¾	2	120	12.0
	10SQ416-*								135	13.5
12	12SQ409-*	2	11'-10	4QDC25	2½	2¾	10	2	140	12.0
	12SQ412-*								156	13.0
	12SQ416-*								204	17
	12SQ509-*	2⅞	11'-9	5QDC3	3	3½	10	3	160	14
	12SQ512-*								178	15
12SQ612-*	3	11'-9	6QDC35	3½	4	¾	3	191	16.5	
12SQ616-*								216	18.0	
12SQ624-*								280	24	
14	14SQ509-*	2⅞	11'-9	5QDC3	3	3½	10	3	185	16
	14SQ512-*								214	18
	14SQ612-*	3	11'-9	6QDC35	3½	4	¾	3	222	19
	14SQ616-*								246	21
14SQ624-*						¾		342	29	
16	16SQ609-*	3	11'-9	6QDC35	3½	4	10	3	210	18
	16SQ612-*								234	20
	16SQ616-*								282	24
	16SQ624-*								365	31
18	18SQ612-*	3	11'-9	6QDC35	3½	4	¾	3	246	21
	18SQ616-*								294	25
	18SQ624-*								425	36
20	20SQ612-*	3	11'-9	6QDC35	3½	4	¾	3	300	26
	20SQ616-*								360	31
	20SQ724-*	3⅞	11'-8	7QDC4	4	4½	¾	4	475	40
24	24SQ712-*	3⅞	11'-8	7QDC4	4	4½	¾	4	410	37
	24SQ716-*								510	43
	24SQ724-*								595	50

* R For Right Hand
* L For Left Hand

Coupling Bolts

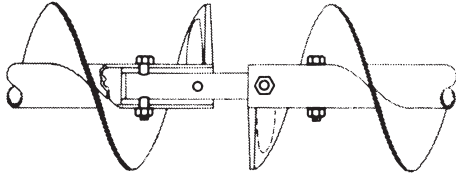

Conveyor coupling bolts are manufactured from special analysis high-torque steel. Close tolerance and no threads inside of the conveyor pipe allow for a minimum of wear. Lock nuts are furnished with each bolt.

Coupling Diameter	Outside Pipe Diameter	Bolt Size	Part Number Standard	Weight Each Lbs.
1	1½	¾ × 2¼	CCB2	.13
1½	2	½ × 3	CCB3	.2
2	2½	⅝ × 3½	CCB4	.45
2⅞	3½	⅝ × 4¾	CCB5	.5
3	4	¾ × 5	CCB6	.85
3	4½	¾ × 5½	CCB6A	.9
3⅞	4½	⅞ × 5½	CCB7	1.29

Internal Collar

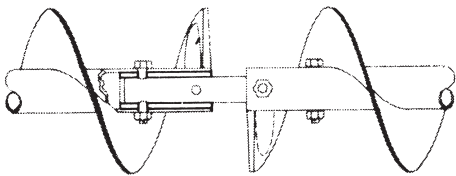

Internal collars are made from seamless tubing machined for a press fit in the conveyor pipe. When installed at the factory collars are jig drilled and plug welded into the pipe. No drilling in replacement collars is furnished allowing for field drilling to match existing bolt holes.

Coupling Diameter	Inside Pipe Diameter	Part Number Standard	Weight Each Lbs.
1	1¼	CIC2	.58
1½	2	CIC3	2.06
2	2½	CIC4	2.16
2⅞	3	CIC5	3.72
3	3½	CIC6	4.03
3	4	CIC6A	8.03
3⅞	4	CIC7	6.52

Discharge End

End Lugs

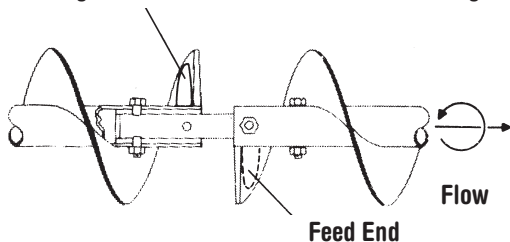

End lugs are welded opposite the carrying side of the conveyor flight and provide maximum support with minimum obstruction of material flow.

Conveyor Diameter	Part Number		Weight Each Lbs.
	Intake End Standard	Discharge End Standard	
6	6CELI-*	6CELD-*	.06
9	9CELI-*	9CELD-*	.15
10	9CELI-*	9CELD-*	.15
12	12CELI-*	12CELD-*	.2
14	12CELI-*	12CELD-*	.2
16	16CELI-*	16CELD-*	.4
18	16CELI-*	16CELD-*	.4
20	16CELI-*	16CELD-*	.4
24	16CELI-*	16CELD-*	.4

* R For Right Hand Flight
* L For Left Hand Flight

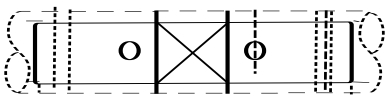
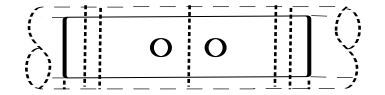
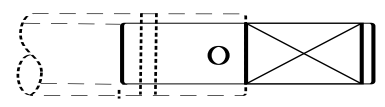
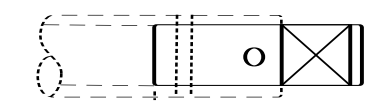
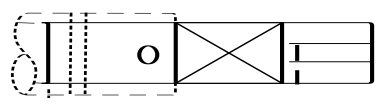
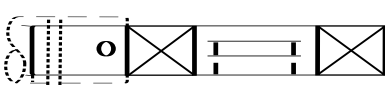
Coupling Shafts		CC	5				
Coupling Part		Coupling Diameter					
CC – Coupling Shaft Std.*		2 – 1"	5 – 2-7/16"	* Add suffix H if Hardened			
CCC – Close Coupling Shaft		3 – 1-1/2"	6 – 3"				
CHE – Hanger End Shaft*		4 – 2"	7 – 3-7/16"				
COUPLING		Conveyor couplings are used to join individual lengths of conveyor screws and allow for rotation within the hanger bearing. C-1045 steel couplings are normally furnished; however couplings with hardened bearing surfaces may be furnished where highly abrasive materials are being conveyed. Jig drilling allows for ease of installation.					
CLOSE		Close couplings are used to adjoin conveyor screws where no hanger is required. Jig drilling allows for ease of installation.					
Drive & End Shafts		1	CD	5	BB	W	Seal Type (Delete if without seal) P – Plate W – Waste Pack
Drive Shaft Number Drive Shaft Only 1 – #1		Type CD – Drive Shaft CE – End Shaft		Coupling Diameter		Bearing Type B – Bronze BB – Ball RB – Roller	
		2 – 1"	3 – 1-1/2"	4 – 2"	5 – 2-7/16"	6 – 3"	7 – 3-7/16"
END		End shafts serve only to support the end conveyor section and are therefore usually supplied in cold rolled steel. End shafts are jig drilled for ease of assembly and close diametral tolerances are held for proper bearing operation.					
HANGER END		Hanger end shafts are designed to connect only one conveyor section to a hanger bearing. These shafts may also be used in pairs to divide an excessively long conveyor assembly between two drives.					
#1 DRIVE		No. 1 drive shafts are normally used where standard end plates are furnished. Jig drilling allows for ease of installation.					
SPECIAL DRIVE		Length, bearing location, seals and keyway location and size as required.					

No. 1 drive shafts are normally used where standard end plates are furnished. Jig drilling allows for ease of installation.

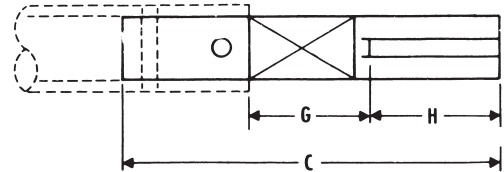

No. 1 Drive Shaft Used Without Seal*											
Bronze Bearing						Ball Bearing					
Shaft Diameter	Part Number	C	G	H	Weight	Shaft Diameter	Part Number	C	G	H	Weight
1	1CD2B	9½	3½	3	2.0	1	1CD2BB	9	3	3	1.8
1½	1CD3B	12¾	4¾	3¼	6.3	1½	1CD3BB	11½	3½	3¼	5.6
2	1CD4B	15	5¾	4½	13.3	2	1CD4BB	13¾	3¾	4½	11.5
2⅝	1CD5B	17¾	7	5½	21.0	2⅝	1CD5BB	15½	4¾	5½	18.0
3	1CD6B	19¾	8¾	6	37.0	3	1CD6BB	16¾	5¾	6	32.0
3⅝	1CD7B	23	9	7¼	60.4	3⅝	1CD7BB	20¾	6¾	7¼	52.5

No. 1 Drive Shaft Used With Plate or Product Drop Out Seals*											
Bronze Bearing						Ball Bearing					
Shaft Diameter	Part Number	C	G	H	Weight	Shaft Diameter	Part Number	C	G	H	Weight
1	1CD2B-P	10	4	3	2.1	1	1CD2BB-P	9½	3½	3	2.0
1½	1CD3B-P	13¾	5¼	3¼	6.6	1½	1CD3BB-P	12¾	4¾	3¼	6.2
2	1CD4B-P	15½	6¼	4½	14.1	2	1CD4BB-P	14	4¾	4½	12.5
2⅝	1CD5B-P	18¾	8	5½	24.3	2⅝	1CD5BB-P	15½	5½	5½	21
3	1CD6B-P	19¾	8¾	6	38.0	3	1CD6BB-P	17½	6½	6	35
3⅝	1CD7B-P	24¾	10¾	7¼	61.0	3⅝	1CD7BB-P	21½	7½	7¼	56.5

No. 1 Drive Shaft Used With Waste Pack Seal*											
Bronze Bearing						Ball Bearing					
Shaft Diameter	Part Number	C	G	H	Weight	Shaft Diameter	Part Number	C	G	H	Weight
1	1CD2B-W	11	4¼	3	2.2	1	1CD2BB-W	10½	3¾	3	2.0
1½	1CD3B-W	14½	6½	3¼	7.2	1½	1CD3BB-W	13¾	5¼	3¼	6.4
2	1CD4B-W	16¾	7½	4½	14.9	2	1CD4BB-W	14¾	5¾	4½	13.0
2⅝	1CD5B-W	19¾	8¾	5½	23.3	2⅝	1CD5BB-W	16¾	6½	5½	20.5
3	1CD6B-W	20¾	9¾	6	40.5	3	1CD6BB-W	18¾	7¾	6	35.5
3⅝	1CD7B-W	25¾	11¾	7¼	66.3	3⅝	1CD7BB-W	22¾	8¾	7¼	58.4

*Shaft length allows for one half hanger bearing length as clearance between end plate and screw

Coupling

Conveyor couplings are used to join individual lengths of conveyor screws and allow for rotation within the hanger bearing. Mild steel couplings are normally furnished; however induction hardened bearing area couplings may be furnished where highly abrasive materials are being conveyed. Jig drilling allows for ease of installation.

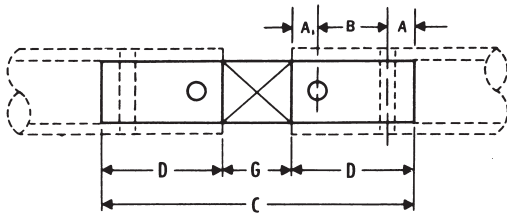

Shaft Diameter	Part Number*	A ₁	A	B	C	D	G	Weight
1	CC2	1/2	1/2	2	7 1/2	3	1 1/2	1.5
1 1/2	CC3	7/8	7/8	3	11 1/2	4 3/4	2	5.6
2	CC4	7/8	7/8	3	11 1/2	4 3/4	2	9.8
2 7/16	CC5	15/16	15/16	3	12 3/4	4 7/8	3	15.4
3	CC6	1	1	3	13	5	3	23.8
3 7/16	CC7	1 1/2	1 1/4	4	17 1/2	6 3/4	4	44.5

*Add — H for Hardened Shaft.

Shaft is induction hardened in bearing area only to 45-50 RC.

Close Coupling

Close couplings are used to adjoin conveyor screws where no hanger is required. Jig drilling allows for ease of installation.

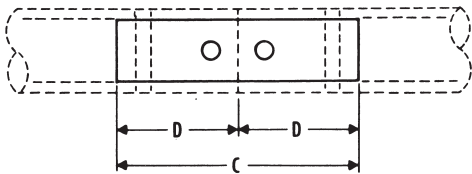

Shaft Diameter	Part Number	C	D	Weight
1	CCC2	6	3	1.3
1 1/2	CCC3	9 1/2	4 3/4	4.8
2	CCC4	9 1/2	4 3/4	8.5
2 7/16	CCC5	9 3/4	4 7/8	12.9
3	CCC6	10	5	20.0
3 7/16	CCC7	13 1/2	6 3/4	37.0

Hanger End

Hanger end shafts are designed to connect only one conveyor section to a hanger bearing. These shafts may also be used in pairs to divide an excessively long conveyor assembly between two drives.

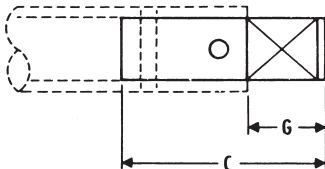

Shaft Diameter	Part Number*	C	G	Weight
1	CHE2	4 5/8	1 5/8	1.0
1 1/2	CHE3	6 7/8	2 1/8	3.5
2	CHE4	6 7/8	2 1/8	6.2
2 7/16	CHE5	8 1/8	3 1/4	10.6
3	CHE6	8 3/4	3 1/4	16.5
3 7/16	CHE7	11 1/4	4 1/4	29.7

*Add — H for Hardened Shaft
Shaft is induction hardened in bearing area only to 45-50 RC.

End shafts serve only to support the end conveyor section and are therefore usually supplied in cold rolled steel. End shafts are jig drilled for ease of assembly and close diametrical tolerances are held for proper bearing operation.

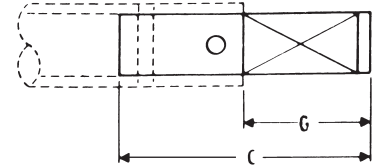

End Shaft Used Without Seal**									
Bronze Bearing					Ball Bearing				
Shaft Diameter	Part Number	C	G	Weight	Shaft Diameter	Part Number*	C	G	Weight
1	CE2B	6½	3½	1.4	1	CE2BB	6	3	1.2
1½	CE3B	9¼	4½	4.5	1½	CE3BB	8¼	3½	3.8
2	CE4B	10¼	5½	9.0	2	CE4BB	8½	3¾	7.5
2⅝	CE5B	11⅞	7	15.4	2⅝	CE5BB	9⅝	4¾	12.4
3	CE6B	13⅝	8½	25.6	3	CE6BB	10⅝	5½	20.8
3⅝	CE7B	16⅜	9¾	42.4	3⅝	CE7BB	13⅜	6½	34.4

End Shaft Used With Plate or Product Drop Out Seal**									
Bronze Bearing					Ball Bearing				
Shaft Diameter	Part Number	C	G	Weight	Shaft Diameter	Part Number*	C	G	Weight
1	CE2B-P	7	4	1.5	1	CE2BB-P	6½	3½	1.4
1½	CE3B-P	10¼	5½	5.1	1½	CE3BB-P	9	4¼	4.5
2	CE4B-P	11¼	6½	10.0	2	CE4BB-P	9⅝	4¾	8.3
2⅝	CE5B-P	12⅞	8	17.0	2⅝	CE5BB-P	10⅝	5¼	13.1
3	CE6B-P	13⅝	8½	29.8	3	CE6BB-P	11½	6½	23.0
3⅝	CE7B-P	16⅜	10⅝	44.0	3⅝	CE7BB-P	14⅝	7¾	37.1

End Shaft Used With Waste Pack Seal**									
Bronze Bearing					Ball Bearing				
Shaft Diameter	Part Number	C	G	Weight	Shaft Diameter	Part Number*	C	G	Weight
1	CE2B-W	8	4¼	1.6	1	CE2BB-W	7½	3¾	1.4
1½	CE3B-W	11	6¼	5.2	1½	CE3BB-W	10	5¼	4.8
2	CE4B-W	12	8¼	10.4	2	CE4BB-W	10⅝	5½	9.0
2⅝	CE5B-W	13⅝	8¾	17.6	2⅝	CE5BB-W	11⅝	6½	14.8
3	CE6B-W	14⅞	9¾	28.2	3	CE6BB-W	12⅝	7¾	24.0
3⅝	CE7B-W	18⅝	11⅞	48.0	3⅝	CE7BB-W	15⅝	8¾	40.2

*Add - H for Hardened Shaft.

**Shaft length allows for one half hanger bearing length, clearance between end plate and screw.

Hanger

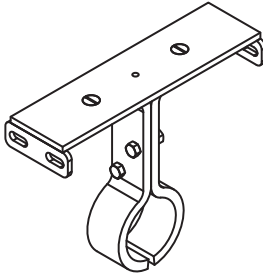
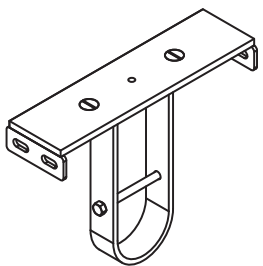
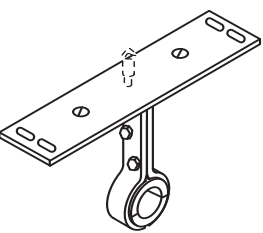
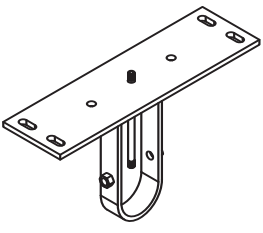
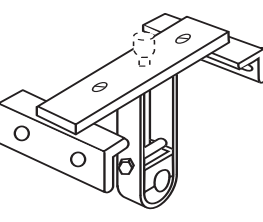
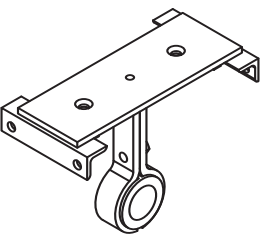
<p>Style 226</p>		<p>No. 226 hangers are designed for flush mounting inside the trough permitting dust-tight or weather-proof operation. This type hanger allows for minimum obstruction of material flow in high capacity conveyors. Available with friction type bearing.</p>
<p>Style 216</p>		<p>No. 216 hangers are designed for heavy duty applications. This hanger is flush mounted inside the trough permitting dust tight or weather proof operation. Hard iron or bronze bearings are normally furnished; however, the hanger can be furnished with other bearings.</p>
<p>Style 220</p>		<p>No. 220 hangers are designed for mount on top of the trough flanges and may be used where dust-tight or weather proof operation is not required. This type hanger allows for minimum obstruction of material flow in high capacity conveyors. Available with friction type bearing.</p>
<p>Style 230</p>		<p>No. 230 hangers are designed for heavy duty applications where mounting on top of the trough flanges is required. Hard iron or bronze bearings are normally furnished; however, other bearings are available.</p>
<p>Style 316</p>		<p>No. 316 hangers are designed for heavy duty use in conveyors where abnormal heat requires unequal expansion between the screw and conveyor trough. Hard iron or bronze bearings are normally furnished; however, this hanger can be furnished with other bearings.</p>
<p>Style 326</p>		<p>No. 326 hangers are designed to permit minimum obstruction of material flow and are used in conveyors where abnormal heat requires unequal expansion between the screw and the conveyor trough. Hard iron or bronze bearings are normally furnished, but other type bearings are available.</p>

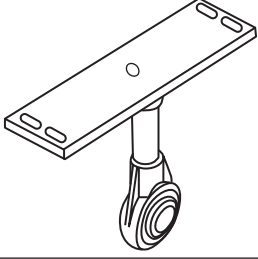
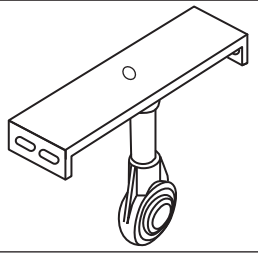
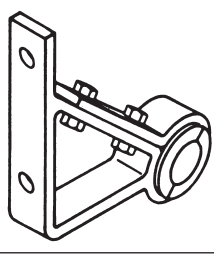
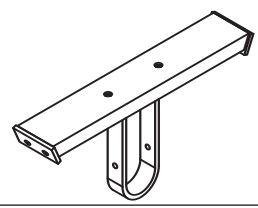
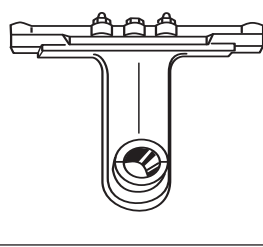
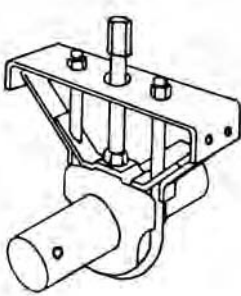
<p>Style 60</p>		<p>No. 60 hangers are furnished with a heavy duty, permanently lubricated and sealed, self aligning ball bearing which permits temperatures up to 245° F. and will allow for up to 4° shaft misalignment. This hanger is mounted on top of the trough flanges. Grease fitting can be furnished if specified.</p>
<p>Style 70</p>		<p>No. 70 hangers are furnished with a heavy duty, permanently lubricated and sealed, self aligning ball bearing which permit temperatures up to 245° F. and will allow for up to 4° shaft misalignment. This hanger is mounted inside the trough. Grease fittings can be furnished if specified.</p>
<p>Style 30</p>		<p>No. 30 hangers are designed for side mounting within the conveyor trough on the noncarrying side and permit a minimum of obstruction of material flow. Available with friction type bearing.</p>
<p>Style 216F</p>		<p>No. 216F hangers are designed for heavy duty applications and are mounted inside of flared trough. Hard iron or bronze bearings are normally furnished; however, other bearings are available.</p>
<p>Style 19B</p>		<p>The No. 19B hangers have a cast iron frame and are mounted on top of the trough angles. Built-in ledges provide supports for the ends of the cover. They are streamline in design and permit free passage of the material. They are regularly furnished with Arguto oil impregnated wood, hard iron, bronze, or other special caps can be furnished.</p>
<p>Air Purged Hanger</p>		<p>Air purged hangers are recommended when handling dusty and abrasive materials which contribute to shutdowns and hanger bearing failures. Air-swept hangers are available for 9"-24" conveyors. They should not be used when handling hot materials (over 250° F) or wet sticky materials or when handling non abrasive materials when an inexpensive hanger will do the job satisfactorily. In service, air-purged hangers deliver relatively trouble-free operation. They help solve noise nuisance problems, and they help reduce power requirement because of the low coefficient of friction. Maximum trough loading should not exceed 15%. The air, at approximately 1-1/4 PSI enters the housing at the top, passes over and around the bearing, and is dissipated around the coupling shaft on both sides of the housing. Thus the bearing is protected from dust and the material in the trough at all times. Only 3 to 7 cu. ft. of air per minute is required to keep each hanger bearing clean.</p>

Hangers

Style 220

No. 220 hangers are designed for mounting on top of the trough flanges and may be used where dust-tight or weather proof operation is not required. This type hanger allows for minimum obstruction of material flow in high capacity conveyors. Available with friction type bearing.

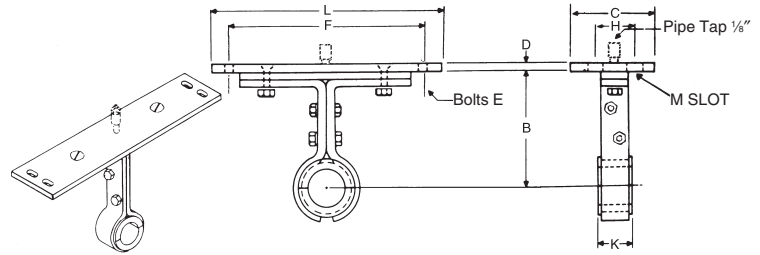

Conveyor Diameter	Coupling Size	Part Number*	B	C	D	E	F	H	K	L	M Slot	Weight Each
4	1	4CH2202	3 ¹ / ₁₆	3 ¹ / ₂	3 ³ / ₁₆	1 ¹ / ₄	6 ¹ / ₂	2	1 ¹ / ₂	7 ¹ / ₄	5 ¹ / ₁₆ × 3 ³ / ₄	5
6	1 ¹ / ₂	6CH2203	4 ¹ / ₂	4 ¹ / ₂	3 ³ / ₁₆	3 ³ / ₈	8 ³ / ₄	2 ¹ / ₂	2	9 ³ / ₄	7 ¹ / ₁₆ × 1 ¹ / ₁₆	7
9	1 ¹ / ₂	9CH2203	6 ¹ / ₈	4 ¹ / ₂	1 ¹ / ₄	3 ³ / ₈	12 ¹ / ₄	2 ¹ / ₂	2	13 ¹ / ₂	7 ¹ / ₁₆ × 1 ¹ / ₁₆	9
	2	9CH2204	6 ¹ / ₈	4 ¹ / ₂	1 ¹ / ₄	3 ³ / ₈	12 ¹ / ₄	2 ¹ / ₂	2	13 ¹ / ₂		11
10	1 ¹ / ₂	10CH2203	6 ³ / ₈	4 ¹ / ₂	1 ¹ / ₄	3 ³ / ₈	13 ³ / ₄	2 ¹ / ₂	2	14 ¹ / ₂	7 ¹ / ₁₆ × 1 ¹ / ₁₆	10
	2	10CH2204	6 ³ / ₈	4 ¹ / ₂	1 ¹ / ₄	3 ³ / ₈	13 ³ / ₄	2 ¹ / ₂	2	14 ¹ / ₂		12
	2 ¹ / ₁₆	12CH2204	7 ³ / ₄	5	3 ³ / ₈	1 ¹ / ₂	15 ³ / ₄	2 ¹ / ₂	2	17 ¹ / ₂	9 ¹ / ₁₆ × 1 ⁵ / ₁₆	16
12	2 ¹ / ₁₆	12CH2205	7 ³ / ₄	5	3 ³ / ₈	1 ¹ / ₂	15 ³ / ₄	2 ¹ / ₂	3	17 ¹ / ₂		21
	3	12CH2206	7 ³ / ₄	5	3 ³ / ₈	1 ¹ / ₂	15 ³ / ₄	2 ¹ / ₂	3	17 ¹ / ₂		28
	2 ⁷ / ₁₆	14CH2205	9 ¹ / ₄	5	1 ¹ / ₂	1 ¹ / ₂	17 ³ / ₄	2 ¹ / ₂	3	19 ¹ / ₂	9 ¹ / ₁₆ × 1 ⁵ / ₁₆	26
14	3	14CH2206	9 ¹ / ₄	5	1 ¹ / ₂	1 ¹ / ₂	17 ³ / ₄	2 ¹ / ₂	3	19 ¹ / ₂		33
	3	16CH2206	10 ³ / ₈	5	1 ¹ / ₂	1 ¹ / ₂	19 ³ / ₄	2 ¹ / ₂	3	21 ¹ / ₂	9 ¹ / ₁₆ × 1 ⁵ / ₁₆	39
18	3	18CH2206	12 ¹ / ₈	6	1 ¹ / ₂	5 ³ / ₈	22 ¹ / ₄	3 ¹ / ₂	3	24 ¹ / ₂	1 ¹ / ₁₆ × 1 ¹ / ₁₆	41
	3 ⁷ / ₁₆	18CH2207	12 ¹ / ₈	6	1 ¹ / ₂	5 ³ / ₈	22 ¹ / ₄	3 ¹ / ₂	4	24 ¹ / ₂		49
20	3	20CH2206	13 ¹ / ₂	6	1 ¹ / ₂	5 ³ / ₈	24 ¹ / ₄	3 ¹ / ₂	3	26 ¹ / ₂	1 ¹ / ₁₆ × 1 ¹ / ₁₆	43
	3 ⁷ / ₁₆	20CH2207	13 ¹ / ₂	6	1 ¹ / ₂	5 ³ / ₈	24 ¹ / ₄	3 ¹ / ₂	4	26 ¹ / ₂		51
24	3 ⁷ / ₁₆	24CH2207	16 ¹ / ₂	6	1 ¹ / ₂	5 ³ / ₈	28 ¹ / ₄	3 ¹ / ₂	4	30 ¹ / ₂	1 ¹ / ₁₆ × 1 ¹ / ₁₆	57

*Refer to Page 76 for bearings

NOTE: For hangers with oil pipe add -O to part number

Style 226

No. 226 hangers are designed for flush mounting inside the trough permitting dust-tight or weather-proof operation. This type hanger allows for minimum obstruction of material flow in high capacity conveyors. Also available with friction type bearing.

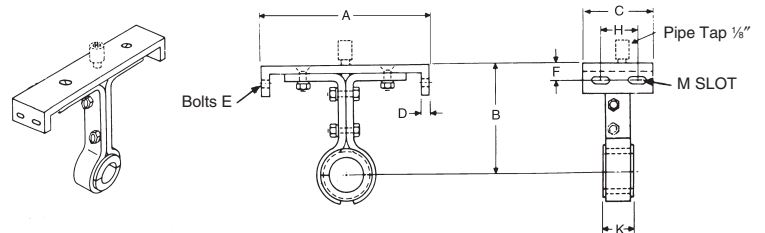

Conveyor Diameter	Coupling Size	Part Number*	A	B	C	D	E	F	H	K	M Slot	Weight Each
4	1	4CH2262	5	3 ³ / ₈	3 ¹ / ₂	3 ³ / ₁₆	1 ¹ / ₄	1 ¹ / ₁₆	2	1 ¹ / ₂	5 ¹ / ₁₆ × 3 ³ / ₄	5
6	1 ¹ / ₂	6CH2263	7	4 ¹ / ₂	4 ¹ / ₂	3 ³ / ₁₆	3 ³ / ₈	3 ³ / ₄	2 ¹ / ₂	2	7 ¹ / ₁₆ × 1 ¹ / ₁₆	7
9	1 ¹ / ₂	9CH2263	10	6 ¹ / ₈	4 ¹ / ₂	1 ¹ / ₄	3 ³ / ₈	1	2 ¹ / ₂	2	7 ¹ / ₁₆ × 1 ¹ / ₁₆	9
	2	9CH2264	10	6 ¹ / ₈	4 ¹ / ₂	1 ¹ / ₄	3 ³ / ₈	1	2 ¹ / ₂	2		11
10	1 ¹ / ₂	10CH2263	11	6 ³ / ₈	4 ¹ / ₂	1 ¹ / ₄	3 ³ / ₈	1	2 ¹ / ₂	2	7 ¹ / ₁₆ × 1 ¹ / ₁₆	10
	2	10CH2264	11	6 ³ / ₈	4 ¹ / ₂	1 ¹ / ₄	3 ³ / ₈	1	2 ¹ / ₂	2		12
	2 ¹ / ₁₆	12CH2264	13	7 ³ / ₄	5	3 ³ / ₈	1 ¹ / ₂	1 ¹ / ₄	2 ¹ / ₂	2	9 ¹ / ₁₆ × 1 ⁵ / ₁₆	16
12	2 ¹ / ₁₆	12CH2265	13	7 ³ / ₄	5	3 ³ / ₈	1 ¹ / ₂	1 ¹ / ₄	2 ¹ / ₂	3		21
	3	12CH2266	13	7 ³ / ₄	5	3 ³ / ₈	1 ¹ / ₂	1 ¹ / ₄	2 ¹ / ₂	3		28
	2 ⁷ / ₁₆	14CH2265	15	9 ¹ / ₄	5	1 ¹ / ₂	1 ¹ / ₂	1 ³ / ₈	2 ¹ / ₂	3	9 ¹ / ₁₆ × 1 ⁵ / ₁₆	26
14	3	14CH2266	15	9 ¹ / ₄	5	1 ¹ / ₂	1 ¹ / ₂	1 ³ / ₈	2 ¹ / ₂	3		33
	3	16CH2266	17	10 ³ / ₈	5	1 ¹ / ₂	1 ¹ / ₂	1 ³ / ₈	2 ¹ / ₂	3	9 ¹ / ₁₆ × 1 ⁵ / ₁₆	39
18	3	18CH2266	19	12 ¹ / ₈	6	1 ¹ / ₂	5 ³ / ₈	1 ¹ / ₂	3 ¹ / ₂	3	1 ¹ / ₁₆ × 1 ¹ / ₁₆	41
	3 ⁷ / ₁₆	18CH2267	19	12 ¹ / ₈	6	1 ¹ / ₂	5 ³ / ₈	1 ¹ / ₂	3 ¹ / ₂	4		49
20	3	20CH2266	21	13 ¹ / ₂	6	1 ¹ / ₂	5 ³ / ₈	1 ¹ / ₂	3 ¹ / ₂	3	1 ¹ / ₁₆ × 1 ¹ / ₁₆	43
	3 ⁷ / ₁₆	20CH2267	21	13 ¹ / ₂	6	1 ¹ / ₂	5 ³ / ₈	1 ¹ / ₂	3 ¹ / ₂	4		51
24	3 ⁷ / ₁₆	24CH2267	25	16 ¹ / ₂	6	1 ¹ / ₂	5 ³ / ₈	1 ³ / ₈	3 ¹ / ₂	4	1 ¹ / ₁₆ × 1 ¹ / ₁₆	57

*Refer to Page 76 for bearings

*For hangers with oil pipe add -O to part number

Style 216

No. 216 hangers are designed for heavy duty applications. This hanger is flush mounted inside the trough permitting dust tight or weather proof operation. Hard iron or bronze bearings are normally furnished; however, the hanger can be furnished with other bearings.

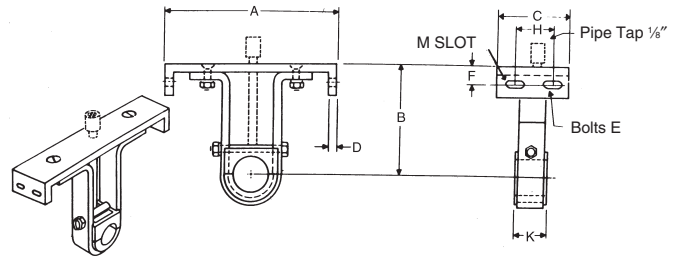

Conveyor Diameter	Coupling Size	Part Number*	A	B	C	D	E	F	H	K	M Slot	Weight Each
6	1½	6CH2163	7	4½	4½	¾	¾	¾	2½	2	7/16 × 1 1/16	5
9	1½	9CH2163	10	6	4½	¼	¾	1	2½	2	7/16 × 1 1/16	7
	2	9CH2164	10	6	4½	¼	¾	1	2½	2	7/16 × 1 1/16	9
10	1½	10CH2163	11	6	4½	¼	¾	1	2½	2	7/16 × 1 1/16	8
	2	10CH2164	11	6	4½	¼	¾	1	2½	2	7/16 × 1 1/16	10
	2	12CH2164	13	7	5	¾	½	1¼	2½	2	9/16 × 1 5/16	14
12	2 2/16	12CH2165	13	7	5	¾	½	1¼	2½	3	9/16 × 1 5/16	18
	3	12CH2166	13	7	5	¾	½	1¼	2½	3	9/16 × 1 5/16	21
	2 2/16	14CH2165	15	9	5	½	½	1½	2½	3	9/16 × 1 5/16	23
14	3	14CH2166	15	9	5	½	½	1½	2½	3	9/16 × 1 5/16	25
	3	16CH2166	17	10	5	½	½	1½	2½	3	9/16 × 1 5/16	28
18	3	18CH2166	19	12	6	½	¾	1½	3½	3	1 1/16 × 1 11/16	34
	3 2/16	18CH2167	19	12	6	½	¾	1½	3½	4	1 1/16 × 1 11/16	44
20	3	20CH2166	21	13	6	½	¾	1½	3½	3	1 1/16 × 1 11/16	36
	3 2/16	20CH2167	21	13	6	½	¾	1½	3½	4	1 1/16 × 1 11/16	47
24	3 2/16	24CH2167	25	16	6	¾	¾	1½	3½	4	1 1/16 × 1 11/16	53

*Refer to Page 76 for bearings

*For hangers with oil pipe add -O to part number

Style 230

No. 230 hangers are designed for heavy duty applications where mounting on top of the trough flange is required. Hard iron or bronze bearings are normally furnished; however, other bearings are available.

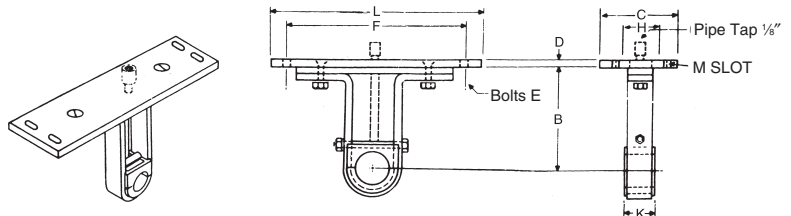

Conveyor Diameter	Coupling Size	Part Number*	B	C	D	E	F	H	K	L	M Slot	Weight Each
6	1½	6CH2303	4½	4½	¼	¾	8¾	2½	2	9¾	7/16 × 1 1/16	6
9	1½	9CH2303	6	4½	¼	¾	12¾	2½	2	13¾	7/16 × 1 1/16	8
	2	9CH2304	6	4½	¼	¾	12¾	2½	2	13¾	7/16 × 1 1/16	10
10	1½	10CH2303	6	4½	¼	¾	13¾	2½	2	14¾	7/16 × 1 1/16	9
	2	10CH2304	6	4½	¼	¾	13¾	2½	2	14¾	7/16 × 1 1/16	11
12	2	12CH2304	7	5	¾	½	15¾	2½	2	17½	9/16 × 1 5/16	15
	2 2/16	12CH2305	7	5	¾	½	15¾	2½	3	17½	9/16 × 1 5/16	20
	3	12CH2306	7	5	¾	½	15¾	2½	3	17½	9/16 × 1 5/16	25
14	2 2/16	14CH2305	9	5	¾	½	17¾	2½	3	19¾	9/16 × 1 5/16	24
	3	14CH2306	9	5	¾	½	17¾	2½	3	19¾	9/16 × 1 5/16	29
16	3	16CH2306	10	5	¾	½	19¾	2½	3	21½	9/16 × 1 5/16	35
	3	18CH2306	12	6	½	¾	22¼	3½	3	24½	1 1/16 × 1 11/16	34
18	3 2/16	18CH2307	12	6	½	¾	22¼	3½	4	24½	1 1/16 × 1 11/16	47
	3	20CH2306	13	6	½	¾	24¼	3½	3	26½	1 1/16 × 1 11/16	40
20	3 2/16	20CH2307	13	6	½	¾	24¼	3½	4	26½	1 1/16 × 1 11/16	49
	3 2/16	24CH2307	16	6	¾	¾	28¾	3¾	4	30½	1 1/16 × 1 11/16	55

*Refer to Page 76 for bearings

*For hangers with oil pipe add -O to part number

Hangers

Style 316

No. 316 hangers are designed for heavy duty use in conveyors where abnormal expansion between the screw and conveyor trough. Hard iron or bronze bearings are normally used; however, this hanger can be furnished with other bearings.

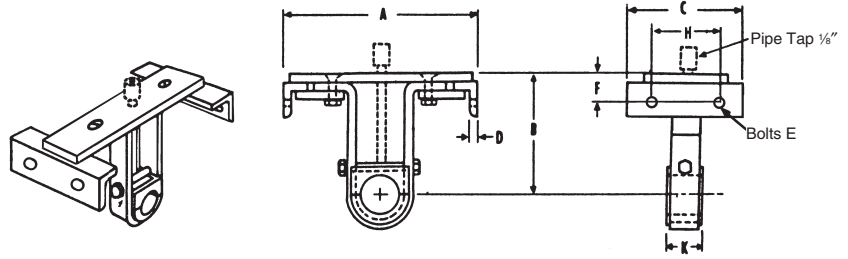

Style 326

No. 326 hangers are designed to permit minimum obstruction of material flow and are used in conveyors where abnormal heat requires unequal expansion between the screw and the conveyor trough. Hard iron or bronze bearings are normally used, but other type bearings are available.

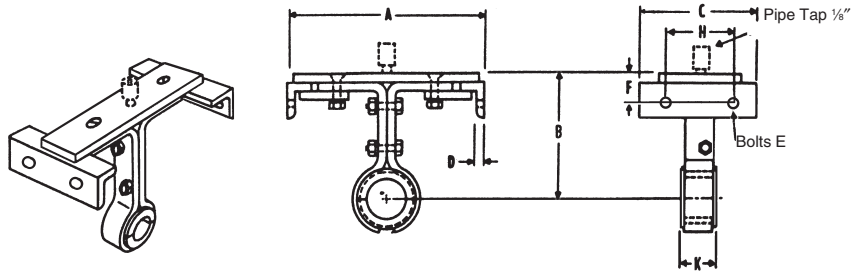

Conveyor Diameter	Coupling Size	Part Number		A	B	C	D	E	F	H	K
		Style 316*	Style 326*								
6	1½	6CH3163	6CH3263	7	4½	6	3/16	3/8	3/4	4½	2
9	1½	9CH3163	9CH3263	10	6¼	6	3/16	3/8	1	4½	2
	2	9CH3164	9CH3264	10	6¼	6	3/16	3/8	1	4½	2
10	1½	10CH3163	10CH3263	11	6¾	6	3/16	3/8	1	4½	2
	2	10CH3164	10CH3264	11	6¾	6	3/16	3/8	1	4½	2
12	2	12CH3164	12CH3264	13	7¾	6½	¼	½	1¼	5	2
	2 7/16	12CH3165	12CH3265	13	7¾	6½	¼	½	1¼	5	3
	3	12CH3166	12CH3266	13	7¾	6½	¼	½	1¼	5	3
14	2 7/16	14CH3165	14CH3265	15	9¼	6½	¼	½	1¾	5	3
	3	14CH3166	14CH3266	15	9¼	6½	¼	½	1¾	5	3
16	3	16CH3166	16CH3266	17	10¾	6½	¼	½	1¾	5	3
	3 7/16	18CH3166	18CH3266	19	12½	6½	¼	¾	1¾	5¼	3
18	3 7/16	18CH3167	18CH3267	19	12½	7	¼	¾	1¾	5¼	4
	3	20CH3166	20CH3266	21	13¾	7	¼	¾	1¾	5¼	3
20	3 7/16	20CH3167	20CH3267	21	13¾	7	¼	¾	1¾	5¼	4
	3 7/16	24CH3167	24CH3267	25	16¼	7	¼	¾	1¾	5¼	4

*Refer to Page 76 for bearings

*For hangers with oil pipe add -O to part number

Air Purged Hanger

Air purged hangers are recommended when handling dusty and abrasive materials which contribute to shut-downs and hanger bearing failures. They should not be used when handling hot materials (over 250°F) or wet sticky materials or when handling nonabrasive materials when an inexpensive hanger will do the job satisfactorily. Maximum trough loading should not exceed 15%. The air, at approximately 1¼ PSI, enters the housing at the top, passes over and around the bearing, and is dissipated around the coupling shaft on both sides of the housing. Only 3 to 7 cu. ft. of air per minute is required to keep each hanger bearing clean.

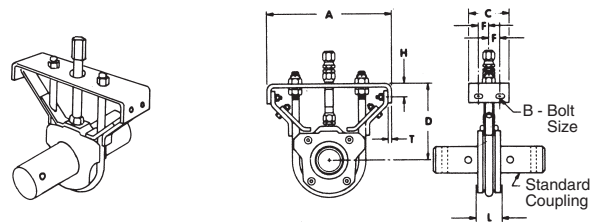

Screw Diameter	Part Number	Shaft Dia.	Weight Each	A	B	C	D	F	H	L	T
9	9CHAPH3	1½	15	10	3/8	4½	6½	1¼	1	2	¼
	9CHAPH4	2	20								
12	12CHAPH4	2	30	13	½	5	7¾	1¼	1¼	2	¼
	12CHAPH5	2 7/16	52								
	12CHAPH6	3	68								
14	14CHAPH5	2 7/16	60	15	½	5	9¼	1¼	1¾	3	3/8
	14CHAPH6	3	74								
16	16CHAPH6	3	77	17	½	5	10¾	1¼	1¾	3	1/8
18	18CHAPH6	3	91	19	¾	6	12½	1¾	1¾	3	½
20	20CHAPH6	3	105	21	¾	6	13½	1¾	1¾	3	½
	20CHAPH7	3 7/16	140								
24	24CHAPH7	3 7/16	155	25	¾	6	16½	1¾	1¾	4	½

Space required on coupling for hanger.
Air supply should be clean and dry.

Dimensions in inches.
Weight in pounds.

Style 30

No. 30 hangers are designed for side mounting within the conveyor trough on the non-carrying side and permit a minimum of obstruction of material flow. Available with friction type bearing.

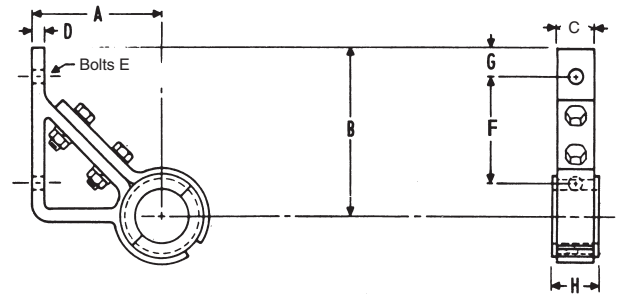
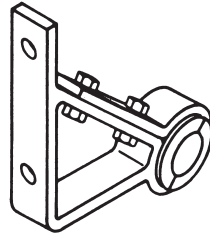

Conveyor Diameter	Coupling Diameter	Part Number*	A	B	C	D	E	F	G	H	Weight Each
6	1½	6CH303	3½	4¼	1½	¾	⅝	3¾	½	2	3
9	1½	9CH303	5	5½	1½	¾	¾	4¼	½	2	6
	2	9CH304	5	5½	1½	½	¾	4¼	½	2	8
10	1½	10CH303	5½	6¾	1½	¾	½	4¾	¾	2	8
	2	10CH304	5½	6¾	1½	½	½	4¾	¾	2	9
12	2	12CH304	6½	7½	1½	½	½	5½	¾	2	12
	2⅞	12CH305	6½	7½	2	½	½	5½	¾	3	18
	3	12CH306	6½	7½	2	½	½	5½	¾	3	20
14	2⅞	14CH305	7½	9	2	½	¾	6¾	¾	3	20
	3	14CH306	7½	9	2	½	¾	6¾	¾	3	22
16	3	16CH306	8½	10¾	2	¾	¾	8	1	3	32
18	3	18CH306	9½	11¾	2	¾	¾	9	1¼	3	30
	3⅞	18CH307	9½	11¾	3	¾	¾	9	1¼	4	33
20	3	20CH306	10½	13¼	2	¾	¾	10¼	1¼	3	32
	3⅞	20CH307	10½	13¼	3	¾	¾	10¼	1¼	4	38
24	3⅞	24CH307	12½	16¼	3	¾	¾	12¾	1½	4	46

*Refer to Page 76 for bearings

NOTE: For hangers with oil pipe add -O to part number

Style 216F

No. 216F hangers are designed for heavy duty applications and are mounted inside of flared trough. Hard iron or bronze bearings are normally furnished; however, other bearings are available.

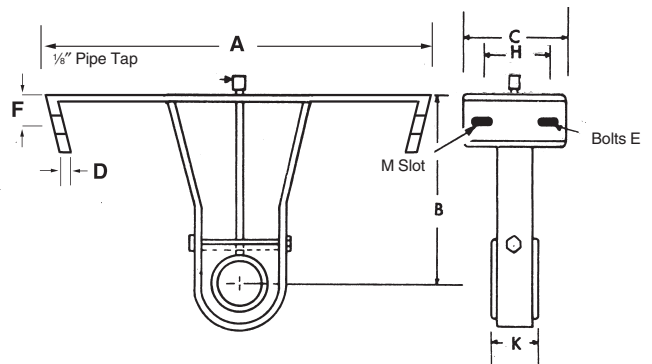
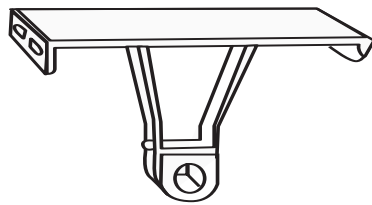

Conveyor Diameter	Coupling Diameter	Part Number*	A	B	C	D	E	F	H	K	Weight Each	M Slot
6	1½	6CH216F3	14	7	4	¾	¾	7/8	2½	2	9	7/16 × ¾
9	1½	9CH216F3	18	9	4	¾	¾	7/8	2½	2	14	7/16 × ¾
	2	9CH216F4									17	
12	2	12CH216F4	22	10	5	¾	½	1⅞	2½	2	24	9/16 × ¾
	2⅞	12CH216F5								28		
	3	12CH216F6								32		
14	2⅞	14CH216F5	24	11	5	¾	½	1⅞	2½	3	31	9/16 × ¾
	3	14CH216F6								34		
16	3	16CH216F6	28	11½	5	¾	½	1⅞	2½	3	38	9/16 × ¾
18	3	18CH216F6	31	12¾	5	½	¾	1½	3½	3	52	11/16 × 7/8
	3⅞	18CH216F7								4	61	
20	3	20CH216F6	34	13½	5	½	¾	1½	3½	3	55	11/16 × 7/8
	3⅞	20CH216F7								4	64	
24	3⅞	24CH216F7	40	16½	5	½	¾	1½	3½	4	71	11/16 × 7/8

*Refer to Page 76 for bearings

NOTE: For hangers with oil pipe add -O to part number

Hangers

Style 60

No. 60 hangers are furnished with a heavy duty, permanently lubricated and sealed, self-aligning ball bearing which permits temperatures up to 245° F. and will allow for up to 4° shaft misalignment. This hanger is mounted on top of the trough flanges. Grease fitting can be furnished if specified.

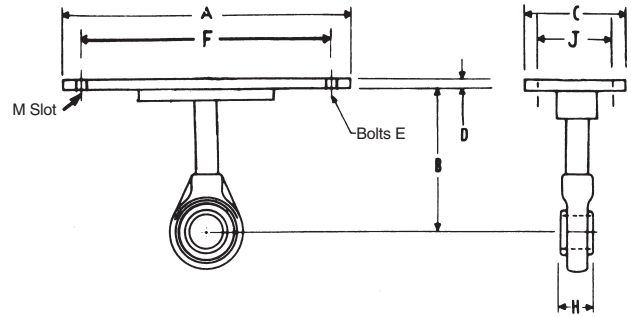
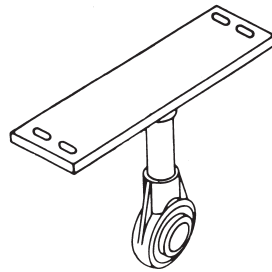

Conveyor Diameter	Coupling Size	Part Number*	A	B	C	D	E	F	H	J	Weight Each	M Slot
6	1½	6CH603	9¾	4½	4	¾	¾	8¾	1⅞	2	7	7/16 × 1 1/16
9	1½	9CH603	13½	6⅞	4	¼	¾	12¼	1⅞	2	8	7/16 × 1 1/16
	2	9CH604	13½	6⅞	4	¼	¾	12¼	1¾	2	9	7/16 × 1 1/16
10	1½	10CH603	14½	6⅞	4	¼	¾	13¼	1⅞	2	9	7/16 × 1 1/16
	2	10CH604	14½	6⅞	4	¼	¾	13¼	1¾	2	10	7/16 × 1 1/16
12	2	12CH604	17½	7¼	5	¾	½	15½	1¾	2½	12	9/16 × 1 1/16
	2 7/16	12CH605	17½	7¼	5	¾	½	15½	1 5/64	2½	20	9/16 × 1 1/16
	3	12CH606	17½	7¼	5	¾	½	15½	2 1/16	2½	30	9/16 × 1 1/16
14	2 7/16	14CH605	19½	9¼	5	½	½	17¾	1 5/64	2½	21	9/16 × 1 1/16
	3	14CH606	19½	9¼	5	½	½	17¾	2 1/32	2½	32	9/16 × 1 1/16
16	3	16CH606	21½	10⅞	5	½	½	19¾	2 1/32	2½	35	9/16 × 1 1/16
18	3	18CH606	24½	12⅞	6	½	¾	22¼	2 1/32	3½	40	1 1/16 × 1 1/16
20	3	20CH606	26½	13½	6	½	¾	24¼	2 1/32	3½	45	1 1/16 × 1 1/16
24	3 7/16	24CH607	30½	16½	6	¾	¾	28¼	2 3/64	3 3/4	58	1 1/16 × 1 1/16

*For hangers with oil pipe add -O to part number

Style 70

No. 70 hangers are furnished with a heavy duty, permanently lubricated and sealed, self-aligning ball bearing which permits temperatures up to 245° F. and will allow for up to 4° shaft misalignment. This hanger is mounted inside the trough. Grease fitting can be furnished if specified.

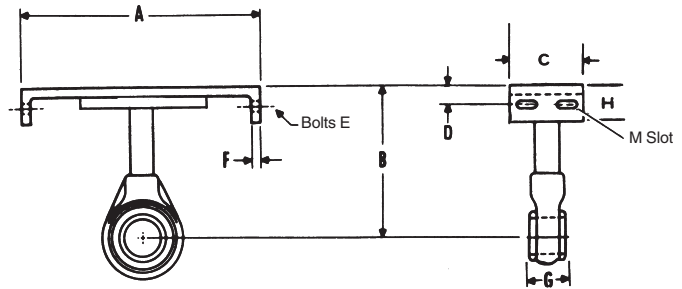

Conveyor Diameter	Coupling Size	Part Number*	A	B	C	D	E	F	G	H	Weight Each	M Slot
6	1½	6CH703	7	4½	4½	¾	¾	¾	1⅞	1½	7	7/16 × 1 1/16
9	1½	9CH703	10	6⅞	4½	1	¾	¼	1⅞	1¾	8	7/16 × 1 1/16
	2	9CH704	10	6⅞	4½	1	¾	¼	1¾	1¾	9	7/16 × 1 1/16
10	1½	10CH703	11	6⅞	4½	1	¾	¼	1⅞	1¾	9	7/16 × 1 1/16
	2	10CH704	11	6⅞	4½	1	¾	¼	1¾	1¾	10	7/16 × 1 1/16
12	2	12CH704	13	7¼	5	1¼	½	¾	1¾	2½	12	9/16 × 1 1/16
	2 7/16	12CH705	13	7¼	5	1¼	½	¾	1 5/64	2½	20	9/16 × 1 1/16
	3	12CH706	13	7¼	5	1¼	½	¾	2 1/32	2½	30	9/16 × 1 1/16
14	2 7/16	14CH705	15	9¼	5	1¾	½	½	1 5/64	2¼	21	9/16 × 1 1/16
	3	14CH706	15	9¼	5	1¾	½	½	2 1/32	2¼	32	9/16 × 1 1/16
16	3	16CH706	17	10⅞	5	1¾	½	½	2 1/32	2¼	35	9/16 × 1 1/16
18	3	18CH706	19	12⅞	6	1½	¾	½	2 1/32	2½	40	1 1/16 × 1 1/16
20	3	20CH706	21	13½	6	1½	¾	½	2 1/32	2½	45	1 1/16 × 1 1/16
24	3 7/16	24CH707	25	16½	6	1¾	¾	¾	2 1/32	2½	58	1 1/16 × 1 1/16

*For hangers with oil pipe add -O to part number

Style 19B

The No. 19-B Hanger has a cast iron frame and bearing cap held in place by a U-bolt. They are mounted on top of the trough angles. Built-in ledges provide supports for the ends of the cover. They are streamlined in design and permit free passage of the material.

They are regularly furnished with Bronze bearings, Arguto oil impregnated wood, hard iron, bronze, or other special caps can be furnished.

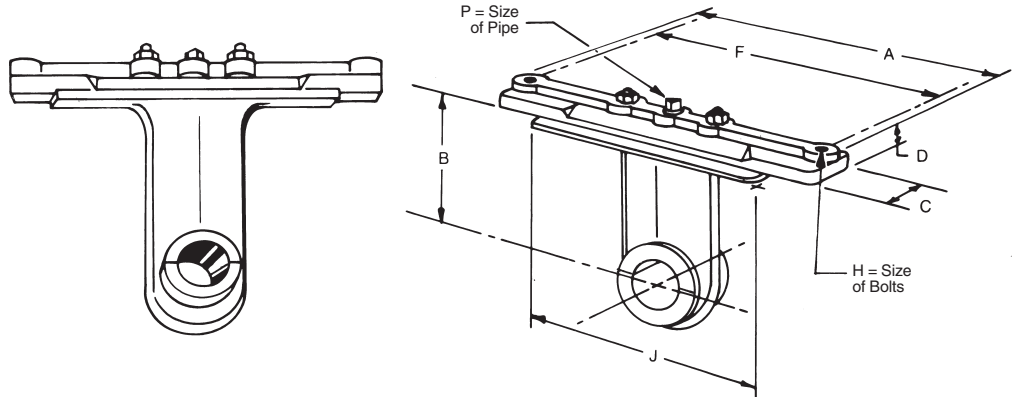

Conveyor Diameter	Bearing Bore	Part Number	Weight	A	B	C	D	F	H Bolt	J	P Pipe
6	1½	6CH19B3	8.5	9¾	4½	1⅞	¾	8¾	½	6½	¼
9	1½ 2	9CH19B3	13	13½	6½	1¾	1	12¼	½	9½	¼
		9CH19B4	15.5	13½	6½	1¾	1	12¼	½	9½	¼
10	1½ 2	10CH19B3	14	14½	6½	1¾	1	13¾	½	10½	¼
		10CH19B4								10½	
12	2 2⅞ 3	12CH19B4	24	17	7¾	2	1¼	15¾	½	12½	¼
		12CH19B5	24.5	17	7¾	2¾	1½	15¾	½	12½	¼
		12CH19B6									12½
14	2⅞ 3	14CH19B5	37	19¾	9¾	2¾	1¾	17¾	½	14½	¼
		14CH19B6								14¾	
16	2⅞ 3	16CH19B5	45	21¼	10½	3	1¾	19¾	¾	16½	¼
		16CH19B6									
18	3	18CH19B6	48.5	23¾	12½	3	1¾	22¼	¾	18½	¼
20	3⅞	20CH19B7	60.0	26¾	13½	4	1⅞	24¼	¾	20	¼

Screw Conveyor Hanger Bearing Selection Application

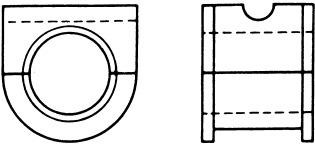

BEARING MATERIAL	MAXIMUM OPERATING TEMP (°F)	STYLES AVAILABLE	MATERIAL FDA APPROVED	SELF LUBE	SOME SUGGESTED USES	COMMENTS
<i>Martin</i> HARD IRON	500°	220		Yes	Chemical, Cement, Aggregate	Requires Hardened shafts.
CAST HARD IRON (45-50 Rockwell C)	500°	220, 216			Lime, Cement, Salt, Gypsum	Requires hardened shaft. Can be noisy. Lubrication required in some applications.
WOOD	160°	220, 216		Yes	Grain, Feed, Fertilizer	Good general purpose.
<i>Martin</i> BRONZE	850°	220		Yes	Grain, Feed, Processing	High quality bearings. High load capacity.
NYLON	250°	220	Yes	Yes	Food and Grain	For dry applications.
PLASTECH	300°	220	Yes	Yes	Chemical, Food, Grain	Good general purpose.
UHMW	225°	220, 216	Yes	Yes	Food	Material USDA approved. Does not swell in water.
STELLITE	1000°	220, 216			Chemical, Cement, Aggregate	Requires Stellite insert in shaft.
INDUSTRIAL GRADE ENGINEERED NYLON	160°	220		Yes	Grain, Feed, Fertilizer	Economical replacement for wood.
WHITE MELAMINE	250°	220	Yes		Food Industry	Recommended for sugar.
FOOD GRADE ENGINEERED NYLON	300°	220	Yes	Yes	Food, Grain, Fertilizer	For dry application.
BALL BEARING	180°	60, 70			Non-abrasive applications	General purpose use.
<i>Martin</i> HDPE	200°	220	Yes	Yes	Grain, Feed, Chemical Handling	Recommended for non-abrasive applications.
CERAMIC	1,000°	220, 216	Yes		Chemical, Cement, Food	Requires Hardened shafts.

Hanger Type	Bore	Part Number	Bearing
216	1½	CHB2163*	
	2	CHB2164*	
230	2⅝	CHB2165*	
	3	CHB2166*	
316	3⅞	CHB2167*	

*H—Cast Hard Iron *W—Wood *O—Oil Hole Top Cap *BR – Bronze *U—UHMW *G—Gatke *C—Ceramic *St—Stellite

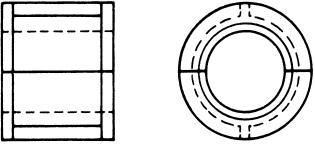
Hanger Type	Bore	Part Number	Bearing
220	1½	CHB2203*	
226	2	CHB2204*	
	2⅝	CHB2205*	
326	3	CHB2206*	
30	3⅞	CHB2207*	

*BR — Bronze *H — Cast Hard Iron *W — Wood *N — Nylatron *P – HDPE *PL - Plastech
 *MHI — *Martin* Hard iron (oil impregnated) *MCB — Melamine *C – Ceramic *WN – White Nylon *ST - Stellite
 *MBR — *Martin* Bronze (oil impregnated) *U — UHMW *UR – Urethane *G - Gatke

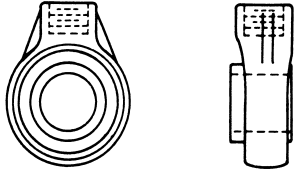
Hanger Type	Bore	Part Number	Bearing
60 Ball Bearing	1½	CHB603	
	2	CHB604	
70 Ball Bearing	2⅝	CHB605	
	3	CHB606	
	3⅞	CHB607	

Note: New style bearings are available with slinger shield one side.

Hanger Type	Bore	Part Number	Bearing
19B	1½	CHB18B3*	
	2	CHB18B4*	
	2⅝	CHB18B5*	
	3	CHB18B6*	
	3⅞	CHB18B7*	

*W—Wood *H—Cast Hard Iron *N—Nylatron *BR—Bronze *G—Gatke

Note: Furnished as bottom cap only

Trough Ends

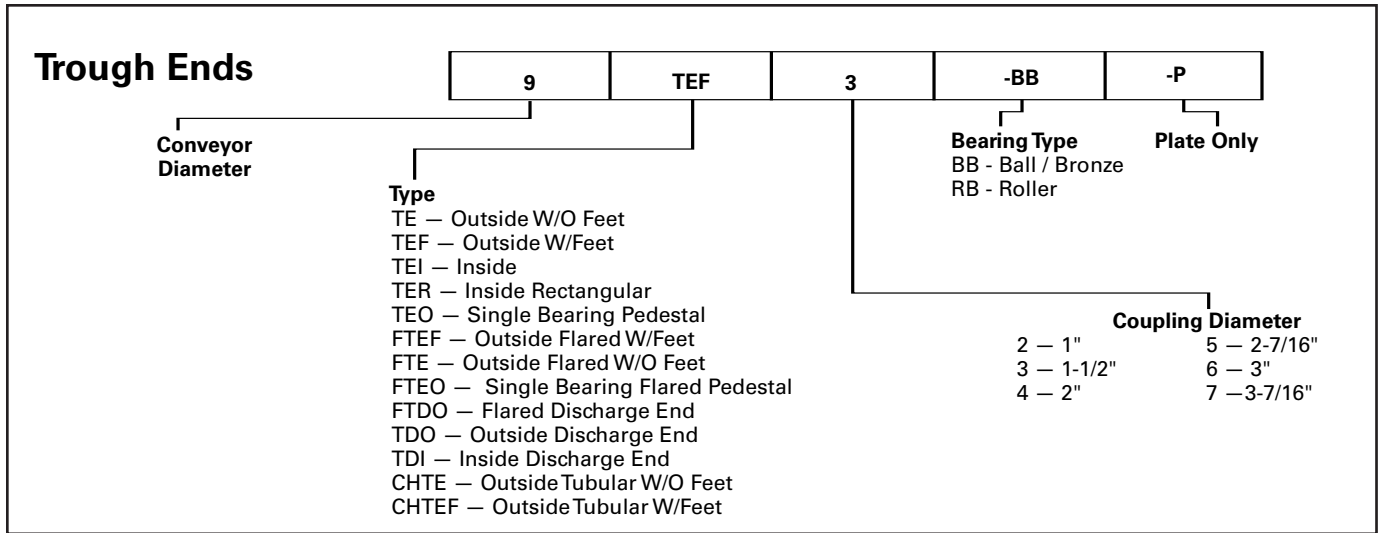

	U-TROUGH	TUBULAR TROUGH	FLARED TROUGH	RECTANGULAR TROUGH	
OUTSIDE TROUGH ENDS WITH FEET					Most common type used as trough support is included.
OUTSIDE TROUGH ENDS WITHOUT FEET					Trough support not included.
INSIDE PATTERN TROUGH ENDS		Available on application	Available on application		Used where space is limited or trough does not have end flange.
DISCHARGE TROUGH ENDS		Available on application			For end discharge conveyors. Special flange bearing required.
OUTBOARD BEARING TROUGH ENDS SINGLE					Used when compression type packing gland seal or split gland seal required.

Outside Less Feet

Outside trough ends less feet are used to support end bearing and cover when no trough support is required. Drilling for bronze bearing or flanged ball bearing is standard.

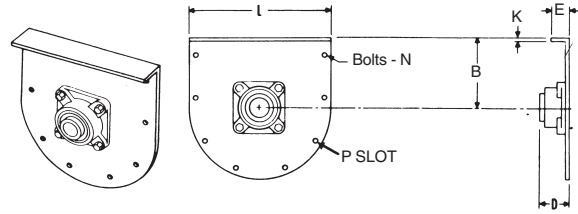

Conveyor Diameter	Shaft Diameter	▲ Part Number	B	D			E	K	L	N	Weight	P Slot
				Friction Bearing	Ball Bearing	Roller Bearing						
4	1	4TE2-*	3 ³ / ₈	2 ³ / ₈	1 ⁵ / ₈		1 ¹ / ₈	¼	8 ¹ / ₈	¾	3	7 ¹ / ₈ × 9 ¹ / ₈
6	1½	6TE3-*	4½	3 ³ / ₈	2 ³ / ₈	3 ¹ / ₈	1½	¼	10 ¹ / ₈	¾	4	7 ¹ / ₈ × 9 ¹ / ₈
9	1½	9TE3-*	6½	3¾	2 ³ / ₈	3 ¹ / ₈	1½	¼	13¾	¾	9	7 ¹ / ₈ × 9 ¹ / ₈
	2	9TE4-*	6½	4¼	2½	3 ¹ / ₈	1½	¼	13¾	¾	9	7 ¹ / ₈ × 9 ¹ / ₈
10	1½	10TE3-*	6½	3¾	2 ³ / ₈	3 ¹ / ₈	1¾	¼	14¾	¾	11	7 ¹ / ₈ × 9 ¹ / ₈
	2	10TE4-*	6½	4¼	2½	3 ¹ / ₈	1¾	¼	14¾	¾	11	7 ¹ / ₈ × 9 ¹ / ₈
12	2	12TE4-*	7¾	4¼	2 ³ / ₈	3¾	2	¼	17¼	½	20	9 ¹ / ₈ × 11 ¹ / ₈
	2 ¹ / ₈	12TE5-*	7¾	5¼	2 ¹ / ₈	4 ¹ / ₈	2	¼	17¼	½	20	9 ¹ / ₈ × 11 ¹ / ₈
	3	12TE6-*	7¾	6¾	3¾	4 ¹ / ₈	2	¼	17¼	½	20	9 ¹ / ₈ × 11 ¹ / ₈
14	2 ¹ / ₈	14TE5-*	9¾	5 ⁵ / ₈	2 ¹ / ₈	4 ¹ / ₈	2	¼	19¾	½	35	9 ¹ / ₈ × 11 ¹ / ₈
	3	14TE6-*	9¾	5 ⁵ / ₈	3¾	4 ¹ / ₈	2	¼	19¾	½	35	9 ¹ / ₈ × 11 ¹ / ₈
16	3	16TE6-*	10 ⁵ / ₈	6 ⁵ / ₈	3 ³ / ₈	5	2½	5 ¹ / ₈	21¼	¾	42	11 ¹ / ₈ × 13 ¹ / ₈
	3	18TE6-*	12½	6¾	3 ³ / ₈	5	2½	¾	24¼	¾	60	11 ¹ / ₈ × 13 ¹ / ₈
18	3	18TE7-*	12½	7¾	4 ³ / ₈	5 ⁵ / ₈	2½	¾	24¼	¾	60	11 ¹ / ₈ × 13 ¹ / ₈
	3 ¹ / ₈	20TE6-*	13½	6¾	3¾	5 ⁵ / ₈	2½	¾	26¾	¾	90	11 ¹ / ₈ × 13 ¹ / ₈
20	3	20TE7-*	13½	7¾	4¾	5¾	2½	¾	26¾	¾	90	11 ¹ / ₈ × 13 ¹ / ₈
	3 ¹ / ₈	24TE7-*	16½	7¾	4¾	5¾	2½	¾	30¼	¾	120	11 ¹ / ₈ × 13 ¹ / ₈

Outside With Feet

Outside trough ends with feet are used to support end bearing, cover and trough. Drilling for bronze bearing or flanged ball bearing is standard.

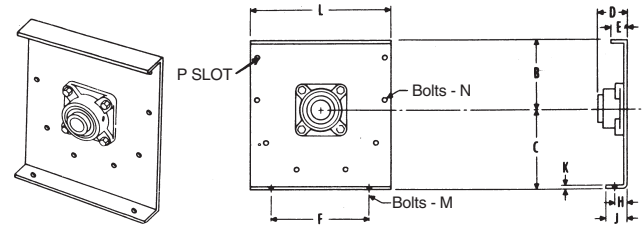

Conveyor Diameter	Shaft Diameter	▲ Part Number	B	C	D			E	F	H	J	K	L	M	N	Weight	P Slot
					Friction Bearing	Ball Bearing	Roller Bearing										
4	1	4TEF2-*	3 ³ / ₈	4 ⁵ / ₈	2 ¹ / ₈	1 ⁵ / ₈	—	1 ¹ / ₈	5¼	1	1 ¹ / ₈	¼	8 ¹ / ₈	¾	¾	4	7 ¹ / ₈ × 9 ¹ / ₈
6	1½	6TEF3-*	4½	5 ⁵ / ₈	3 ³ / ₈	2 ³ / ₈	3 ¹ / ₈	1½	8 ¹ / ₈	1	1¼	¼	10 ¹ / ₈	¾	¾	7	7 ¹ / ₈ × 9 ¹ / ₈
9	1½	9TEF3-*	6½	7¾	3 ³ / ₈	2 ³ / ₈	3 ¹ / ₈	1½	9 ⁵ / ₈	1½	2 ³ / ₈	¼	13¾	½	¾	12	7 ¹ / ₈ × 9 ¹ / ₈
	2	9TEF4-*	6½	7¾	4 ¹ / ₈	2½	3 ¹ / ₈	1½	9 ⁵ / ₈	1½	2 ³ / ₈	¼	13¾	½	¾	12	7 ¹ / ₈ × 9 ¹ / ₈
10	1½	10TEF3-*	6½	8 ¹ / ₈	3 ³ / ₈	2 ³ / ₈	3 ¹ / ₈	1¾	9½	1¾	2 ³ / ₈	¼	14¾	½	¾	14	7 ¹ / ₈ × 9 ¹ / ₈
	2	10TEF4-*	6½	8 ¹ / ₈	4 ¹ / ₈	2½	3 ¹ / ₈	1¾	9½	1¾	2 ³ / ₈	¼	14¾	½	¾	14	7 ¹ / ₈ × 9 ¹ / ₈
12	2	12TEF4-*	7¾	9 ⁵ / ₈	5	2 ³ / ₈	3 ³ / ₈	2	12¼	1 ⁵ / ₈	2¼	¼	17¼	¾	½	23	9 ¹ / ₈ × 11 ¹ / ₈
	2 ¹ / ₈	12TEF5-*	7¾	9 ⁵ / ₈	5½	2 ¹ / ₈	4 ¹ / ₈	2	12¼	1 ⁵ / ₈	2¼	¼	17¼	¾	½	23	9 ¹ / ₈ × 11 ¹ / ₈
	3	12TEF6-*	7¾	9 ⁵ / ₈	5¾	3¾	4 ¹ / ₈	2	12¼	1 ⁵ / ₈	2¼	¼	17¼	¾	½	23	9 ¹ / ₈ × 11 ¹ / ₈
14	2 ¹ / ₈	14TEF5-*	9¾	10 ⁵ / ₈	5½	2 ¹ / ₈	4 ¹ / ₈	2	13½	1 ⁵ / ₈	2 ³ / ₈	¼	19¾	¾	½	38	9 ¹ / ₈ × 11 ¹ / ₈
	3	14TEF6-*	9¾	10 ⁵ / ₈	5¾	3¾	4 ¹ / ₈	2	13½	1 ⁵ / ₈	2 ³ / ₈	¼	19¾	¾	½	38	9 ¹ / ₈ × 11 ¹ / ₈
16	3	16TEF6-*	10 ⁵ / ₈	12	5 ¹ / ₈	3 ³ / ₈	5	2½	14 ⁵ / ₈	2	3¼	5 ¹ / ₈	21¼	¾	¾	45	11 ¹ / ₈ × 13 ¹ / ₈
	3	18TEF6-*	12½	13 ³ / ₈	5 ¹ / ₈	3 ³ / ₈	5	2½	16	2	3¼	¾	24¼	¾	¾	67	11 ¹ / ₈ × 13 ¹ / ₈
18	3 ¹ / ₈	18TEF7-*	12½	13 ³ / ₈	6 ¹ / ₈	4 ³ / ₈	5 ⁵ / ₈	2½	16	2	3¼	¾	24¼	¾	¾	67	11 ¹ / ₈ × 13 ¹ / ₈
	3	20TEF6-*	13½	15	5¼	3¾	5 ⁵ / ₈	2½	19¼	2¼	3¾	¾	26¾	¾	¾	120	11 ¹ / ₈ × 13 ¹ / ₈
20	3 ¹ / ₈	20TEF7-*	13½	15	7	4¾	5¾	2½	19¼	2¼	3¾	¾	26¾	¾	¾	120	11 ¹ / ₈ × 13 ¹ / ₈
	3 ¹ / ₈	24TEF7-*	16½	18 ⁵ / ₈	7	4¾	5¾	2½	20	2½	4¼	¾	30¼	¾	¾	162	11 ¹ / ₈ × 13 ¹ / ₈

▲ Can be furnished with CSP, CSW, or CSFP seals

-*BB Ball / Bronze Bearing

-*RB Roller Bearing
-*P Less Bearing

Trough Ends

Inside

Inside trough ends are used in place of outside type where no trough end flanges are required. Drilling for bronze bearings or flanged ball bearing is standard.

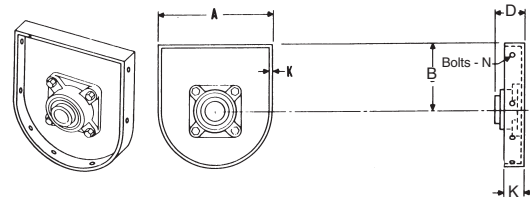

Conveyor Diameter	Shaft Diameter	▲ Part Number	A	B	D			E	K	N	Weight
					Friction Bearing	Ball Bearing	Roller Bearing				
4	1	4TEI2-*	5	3 $\frac{3}{8}$	2 $\frac{3}{16}$	1 $\frac{1}{2}$	—	2	$\frac{1}{4}$	$\frac{1}{4}$	3
6	1 $\frac{1}{2}$	6TEI3-*	7	4 $\frac{1}{2}$	3 $\frac{3}{16}$	2 $\frac{3}{16}$	3 $\frac{1}{16}$	2	$\frac{1}{4}$	$\frac{5}{16}$	5
9	1 $\frac{1}{2}$	9TEI3-*	10	6 $\frac{1}{8}$	3 $\frac{1}{4}$	2 $\frac{3}{16}$	3 $\frac{1}{16}$	2	$\frac{1}{4}$	$\frac{3}{8}$	9
	2	9TEI4-*	10	6 $\frac{1}{8}$	4 $\frac{1}{4}$	2 $\frac{1}{2}$	3 $\frac{3}{16}$	2	$\frac{1}{4}$	$\frac{3}{8}$	9
10	1 $\frac{1}{2}$	10TEI3-*	11	6 $\frac{3}{8}$	3 $\frac{1}{4}$	2 $\frac{3}{16}$	3 $\frac{1}{16}$	2	$\frac{1}{4}$	$\frac{3}{8}$	11
	2	10TEI4-*	11	6 $\frac{3}{8}$	4 $\frac{1}{4}$	2 $\frac{1}{2}$	3 $\frac{3}{16}$	2	$\frac{1}{4}$	$\frac{3}{8}$	11
12	2	12TEI4-*	13	7 $\frac{1}{4}$	4 $\frac{1}{4}$	2 $\frac{3}{16}$	3 $\frac{3}{8}$	2	$\frac{1}{4}$	$\frac{1}{2}$	19
	2 $\frac{1}{16}$	12TEI5-*	13	7 $\frac{1}{4}$	5 $\frac{1}{4}$	2 $\frac{3}{16}$	4 $\frac{1}{16}$	2	$\frac{1}{4}$	$\frac{1}{2}$	19
	3	12TEI6-*	13	7 $\frac{1}{4}$	6 $\frac{1}{4}$	3 $\frac{3}{8}$	4 $\frac{1}{8}$	2	$\frac{1}{4}$	$\frac{1}{2}$	19
14	2 $\frac{1}{16}$	14TEI5-*	15	9 $\frac{1}{4}$	5 $\frac{1}{16}$	2 $\frac{3}{16}$	4 $\frac{1}{16}$	2	$\frac{1}{4}$	$\frac{1}{2}$	34
	3	14TEI6-*	15	9 $\frac{1}{4}$	6 $\frac{3}{16}$	3 $\frac{3}{4}$	4 $\frac{1}{8}$	2	$\frac{1}{4}$	$\frac{1}{2}$	34
16	3	16TEI6-*	17	10 $\frac{3}{8}$	6 $\frac{3}{16}$	3 $\frac{3}{16}$	5	2	$\frac{5}{16}$	$\frac{3}{8}$	40
	3	18TEI6-*	19	12 $\frac{1}{8}$	6 $\frac{3}{8}$	3 $\frac{3}{16}$	5	2	$\frac{3}{8}$	$\frac{3}{8}$	58
18	3 $\frac{1}{16}$	18TEI7-*	19	12 $\frac{1}{8}$	7 $\frac{3}{8}$	4 $\frac{3}{16}$	5 $\frac{1}{16}$	2	$\frac{3}{8}$	$\frac{3}{8}$	58
	3	20TEI6-*	21	13 $\frac{1}{2}$	6 $\frac{3}{8}$	3 $\frac{3}{8}$	5 $\frac{1}{16}$	2	$\frac{3}{8}$	$\frac{3}{8}$	83
20	3 $\frac{1}{16}$	20TEI7-*	21	13 $\frac{1}{2}$	7 $\frac{3}{8}$	4 $\frac{3}{8}$	5 $\frac{3}{8}$	2	$\frac{3}{8}$	$\frac{3}{8}$	83
	3 $\frac{1}{16}$	24TEI7-*	25	16 $\frac{1}{2}$	7 $\frac{3}{8}$	4 $\frac{3}{8}$	5 $\frac{3}{8}$	2	$\frac{3}{8}$	$\frac{3}{8}$	116

Inside Rectangular

Rectangular trough ends are used inside of rectangular trough. Drilling for bronze bearing or flanged ball bearing is standard.

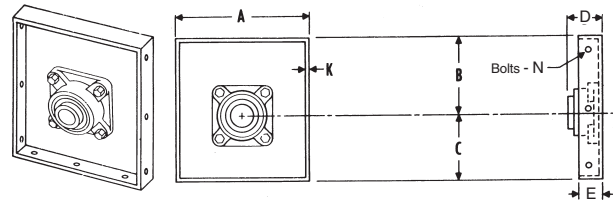

Conveyor Diameter	Shaft Diameter	▲ Part Number	A	B	C	D			E	K	N	Weight
						Friction Bearing	Ball Bearing	Roller Bearing				
4	1	4TER2-*	5	3 $\frac{3}{8}$	2 $\frac{1}{2}$	2 $\frac{3}{16}$	1 $\frac{1}{2}$	—	2	$\frac{1}{4}$	$\frac{1}{4}$	4
6	1 $\frac{1}{2}$	6TER3-*	7	4 $\frac{1}{2}$	3 $\frac{1}{2}$	3 $\frac{3}{16}$	2 $\frac{3}{16}$	3 $\frac{1}{16}$	2	$\frac{1}{4}$	$\frac{5}{16}$	6
9	1 $\frac{1}{2}$	9TER3-*	10	6 $\frac{1}{8}$	5	3 $\frac{1}{4}$	2 $\frac{3}{16}$	3 $\frac{1}{16}$	2	$\frac{1}{4}$	$\frac{3}{8}$	9
	2	9TER4-*	10	6 $\frac{1}{8}$	5	4 $\frac{1}{4}$	2 $\frac{1}{2}$	3 $\frac{3}{16}$	2	$\frac{1}{4}$	$\frac{3}{8}$	9
10	1 $\frac{1}{2}$	10TER3-*	11	6 $\frac{3}{8}$	5 $\frac{1}{2}$	3 $\frac{1}{4}$	2 $\frac{3}{16}$	3 $\frac{1}{16}$	2	$\frac{1}{4}$	$\frac{3}{8}$	12
	2	10TER4-*	11	6 $\frac{3}{8}$	5 $\frac{1}{2}$	4 $\frac{1}{4}$	2 $\frac{1}{2}$	3 $\frac{3}{16}$	2	$\frac{1}{4}$	$\frac{3}{8}$	12
12	2	12TER4-*	13	7 $\frac{1}{4}$	6 $\frac{1}{2}$	4 $\frac{1}{4}$	2 $\frac{3}{16}$	3 $\frac{3}{8}$	2	$\frac{1}{4}$	$\frac{1}{2}$	21
	2 $\frac{1}{16}$	12TER5-*	13	7 $\frac{1}{4}$	6 $\frac{1}{2}$	5 $\frac{1}{4}$	2 $\frac{3}{16}$	4 $\frac{1}{16}$	2	$\frac{1}{4}$	$\frac{1}{2}$	21
	3	12TER6-*	13	7 $\frac{1}{4}$	6 $\frac{1}{2}$	6 $\frac{1}{4}$	3 $\frac{3}{8}$	4 $\frac{1}{8}$	2	$\frac{1}{4}$	$\frac{1}{2}$	21
14	2 $\frac{1}{16}$	14TER5-*	15	9 $\frac{1}{4}$	7 $\frac{1}{2}$	5 $\frac{1}{16}$	2 $\frac{3}{16}$	4 $\frac{1}{16}$	2	$\frac{1}{4}$	$\frac{1}{2}$	35
	3	14TER6-*	15	9 $\frac{1}{4}$	7 $\frac{1}{2}$	6 $\frac{3}{16}$	3 $\frac{3}{4}$	4 $\frac{1}{8}$	2	$\frac{1}{4}$	$\frac{1}{2}$	35
16	3	16TER6-*	17	10 $\frac{3}{8}$	8 $\frac{1}{2}$	6 $\frac{3}{16}$	3 $\frac{3}{16}$	5	2	$\frac{5}{16}$	$\frac{3}{8}$	41
	3	18TER6-*	19	12 $\frac{1}{8}$	9 $\frac{1}{2}$	6 $\frac{3}{8}$	3 $\frac{3}{16}$	5	2	$\frac{3}{8}$	$\frac{3}{8}$	60
18	3 $\frac{1}{16}$	18TER7-*	19	12 $\frac{1}{8}$	9 $\frac{1}{2}$	7 $\frac{3}{8}$	4 $\frac{3}{16}$	5 $\frac{1}{16}$	2	$\frac{3}{8}$	$\frac{3}{8}$	60
	3	20TER6-*	21	13 $\frac{1}{2}$	10 $\frac{1}{2}$	6 $\frac{3}{8}$	3 $\frac{3}{8}$	5 $\frac{1}{16}$	2	$\frac{3}{8}$	$\frac{3}{8}$	88
20	3 $\frac{1}{16}$	20TER7-*	21	13 $\frac{1}{2}$	10 $\frac{1}{2}$	7 $\frac{3}{8}$	4 $\frac{3}{8}$	5 $\frac{3}{8}$	2	$\frac{3}{8}$	$\frac{3}{8}$	88
	3 $\frac{1}{16}$	24TER7-*	25	16 $\frac{1}{2}$	12 $\frac{1}{2}$	7 $\frac{3}{8}$	4 $\frac{3}{8}$	5 $\frac{3}{8}$	2	$\frac{3}{8}$	$\frac{3}{8}$	125

▲ Can be furnished with CSP, CSW, or CSS seals

—*BB Ball / Bronze Bearing

—*RB Roller Bearing
—*P Less Bearing

Single Bearing

Single bearing pedestal type trough ends are constructed with base for mounting pillow block bearings and shaft seal or packing gland.

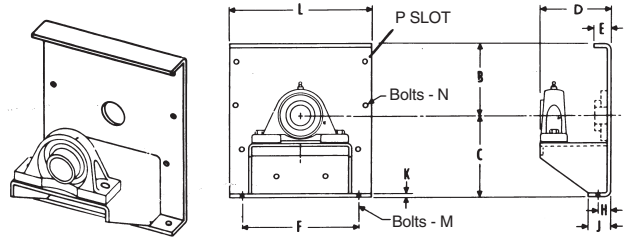

Conveyor Diameter	Shaft Diameter	Part Number	B	C	D	E	F	H	J	K	L	M	N	P Slot	Weight
6	1½	6TEO3													
9	1½ 2	9TEO3 9TEO4													
10	1½ 2	10TEO3 10TEO4													
12	2 2 ² / ₁₆ 3	12TEO4 12TEO5 12TEO6													
14	2 ² / ₁₆ 3	14TEO5 14TEO6													
16	3	16TEO6													
18	3 3 ³ / ₁₆	18TEO6 18TEO7													
20	3 3 ³ / ₁₆	20TEO6 20TEO7													
24	3 ³ / ₁₆	24TEO7													

**Consult
Factory**

Trough Ends

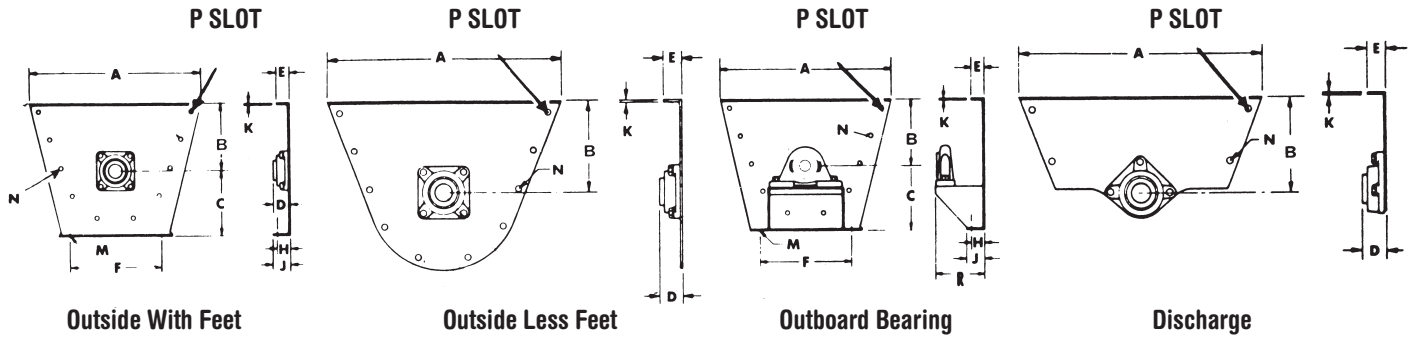

Application: same as standard trough ends except for flared trough.

Conveyor Diameter	Shaft Diameter	A	B	C	D			E	F	H	J	K	M	N	R	P Slot
					Friction Bearing	Ball Bearing	Roller Bearing									
6	1½	16⅞	7	5⅝	3⅜	2⅜	3¼	1½	8⅞	1	1¼	¼	⅜	⅜	Consult Factory	7/16 × 9/16
9	1½ 2	21¼ 21¼	9 9	7⅞ 7⅞	3¼ 4¼	2⅜ 2½	3¼ 3⅞	1⅞ 1⅞	9⅞ 9⅞	1½ 1½	2⅞ 2⅞	¼ ¼	½ ½	⅜ ⅜		7/16 × 9/16 7/16 × 9/16
12	2	26⅞	10	9⅞	4¼	2⅞	3⅞	2	12¼	1⅞	2¼	¼	⅝	½		9/16 × 11/16
	2⅞	26⅞	10	9⅞	5¼	2⅞	4½	2	12¼	1⅞	2¼	¼	⅝	½		9/16 × 11/16
	3	26⅞	10	9⅞	6¼	3⅞	5	2	12¼	1⅞	2¼	¼	⅝	½		9/16 × 11/16
14	2⅞	28⅞	11	10⅞	5⅞	2⅞	4½	2	13½	1⅞	2⅞	¼	⅝	½		9/16 × 11/16
	3	28⅞	11	10⅞	6⅞	3⅞	5	2	13½	1⅞	2⅞	¼	⅝	½		9/16 × 11/16
16	3	32½	11½	12	6⅞	3⅞	5	2½	14⅞	2	3¼	⅝	⅝	⅝		11/16 × 13/16
	18	3	36½	12⅞	13⅞	6⅞	3⅞	5	2½	16	2	3¼	⅝	⅝	⅝	11/16 × 13/16
3⅞		36½	12⅞	13⅞	7⅞	4⅞	5⅞	2½	16	2	3¼	⅝	⅝	⅝	11/16 × 13/16	
20	3	39⅞	13⅞	15	6⅞	3⅞	5	2½	19¼	2¼	3¼	⅝	¾	⅝	11/16 × 13/16	
	3⅞	39⅞	13⅞	15	7⅞	4⅞	5⅞	2½	19¼	2¼	3¼	⅝	¾	⅝	11/16 × 13/16	
24	3⅞	45½	16½	18⅞	7⅞	4⅞	5⅞	2½	20	2½	4¼	⅝	¾	⅝	11/16 × 13/16	

Conveyor Diameter	Shaft Diameter	Part Number							
		Outside With Feet	Weight	Outside Less Feet	Weight	Outboard Bearing	Weight	Discharge	Weight
6	1½	6FTEF3-*	15	6FTE3-*	13	6FTEO3-*	22	6FTDO3-**	11
9	1½	9FTEF3-*	22	9FTE3-*	19	9FTEO3-*	31	9FTDO3-**	15
	2	9FTEF4-*	27	9FTE4-*	24	9FTEO4-*	36	9FTDO4-**	20
12	2	12FTEF4-*	43	12FTE4-*	36	12FTEO4-*	63	12FTDO4-**	28
	2⅞	12FTEF5-*	44	12FTE5-*	37	12FTEO5-*	64	12FTDO5-**	29
	3	12FTEF6-*	56	12FTE6-*	49	12FTEO6-*	76	12FTDO6-**	41
14	2⅞	14FTEF5-*	52	14FTE5-*	43	14FTEO5-*	75	14FTDO5-**	33
	3	14FTEF6-*	64	14FTE6-*	55	14FTEO6-*	87	14FTDO6-**	45
16	3	16FTEF6-*	85	16FTE6-*	72	16FTEO6-*	125	16FTDO6-**	56
	18	3	18FTEF6-*	98	18FTE6-*	83	18FTEO6-*	138	18FTDO6-**
3⅞		18FTEF7-*	104	18FTE7-*	89	18FTEO7-*	144	18FTDO7-**	69
20	3	20FTEF6-*	133	20FTE6-*	103	20FTEO6-*	196	20FTDO6-**	75
	3⅞	20FTEF7-*	139	20FTE7-*	109	20FTEO7-*	202	20FTDO7-**	81
24	3⅞	24FTEF7-*	179	24FTE7-*	132	24FTEO7-*	250	24FTDO7-**	96

-*BB Ball / Bronze Bearing
-*RB Roller Bearing
-*P Less Bearing

-**BB Ball / Bronze Bearing
-**P Less Bearing

For Bolt Pattern see Page page 43

Outside Discharge

Outside discharge trough ends are used to support end bearing and will allow material to discharge or overflow through the end of the trough. Drilling for three bolt bronze or flanged ball bearing is standard.

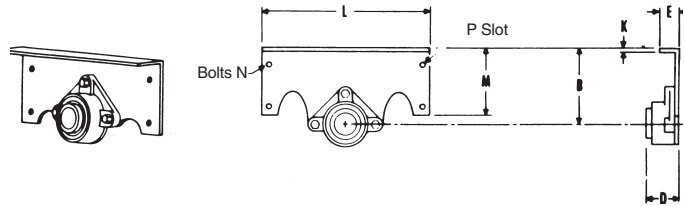

Conveyor Diameter	Shaft Diameter	Part Number	B	D			E	K	L	M	N	P Slot	Weight
				Friction Bearing	Ball Bearing	Roller Bearing							
4	1	4TDO2-*	3 ⁵ / ₁₆	2 ¹ / ₁₆	1 ⁵ / ₁₆	2	1/4	8	3 ⁵ / ₁₆	3/8	7/16 × 9/16	2	
6	1 1/2	6TDO3-*	4 1/2	3 ³ / ₁₆	2 ¹ / ₁₆	3 1/16	2	1/4	9 3/4	4 1/2	3/8	7/16 × 9/16	3
9	1 1/2	9TDO3-*	6 1/8	3 1/4	2 ¹ / ₁₆	3 1/16	2	1/4	13 3/4	6 1/8	3/8	7/16 × 9/16	5
	2	9TDO4-*	6 1/8	4 1/4	2 1/2	3 3/16	2	1/4	13 3/4	6 1/8	3/8	7/16 × 9/16	5
10	1 1/2	10TDO3-*	6 3/8	3 3/4	2 ¹ / ₁₆	3 1/16	2	1/4	14 3/4	6 3/8	3/8	7/16 × 9/16	6
	2	10TDO4-*	6 3/8	4 1/4	2 1/2	3 3/16	2	1/4	14 3/4	6 3/8	3/8	7/16 × 9/16	6
12	2	12TDO4-*	7 3/4	4 1/4	2 ¹ / ₁₆	3 3/8	2	1/4	17 1/2	7 3/4	1/2	9/16 × 3/4	12
	2 1/16	12TDO5-*	7 3/4	5 1/4	2 ¹ / ₁₆	4 7/16	2	1/4	17 1/2	7 3/4	1/2	9/16 × 3/4	12
	3	12TDO6-*	7 3/4	6 1/4	3 3/4	4 15/16	2	1/4	17 1/2	7 3/4	1/2	9/16 × 3/4	12
14	2 1/16	14TDO5-*	9 1/4	5 5/16	2 ¹ / ₁₆	4 7/16	2	1/4	19 1/4	9 1/4	5/8	9/16 × 3/4	17
	3	14TDO6-*	9 1/4	6 5/16	3 3/4	4 15/16	2	1/4	19 1/4	9 1/4	5/8	9/16 × 3/4	17
16	3	16TDO6-*	10 5/8	6 5/16	3 3/16	5	2	5/16	21 1/8	10 5/8	5/8	1 1/16 × 7/8	26
	3	18TDO6-*	12 1/8	6 3/8	3 3/16	5	2	3/8	23 1/2	12 1/8	5/8	1 1/16 × 7/8	33
18	3 3/16	18TDO7-*	12 3/8	7 3/8	4 1/16	5 5/16	2	3/8	23 1/2	12 3/8	5/8	1 1/16 × 7/8	33
	3	20TDO6-*	13 1/2	6 3/8	3 3/8	5 1/16	2	3/8	26 3/4	13 1/2	5/8	1 1/16 × 7/8	55
20	3 3/16	20TDO7-*	13 1/2	7 3/8	4 3/8	5 5/8	2	3/8	26 3/4	13 1/2	5/8	1 1/16 × 7/8	55
	3 3/16	24TDO7-*	16 1/2	7 3/8	4 3/8	5 5/8	2	3/8	30 1/2	16 1/2	5/8	1 1/16 × 7/8	81

Inside Discharge

Inside discharge trough ends are used to support end bearing and will allow material to discharge or overflow through the end of the trough. This trough end is used inside the trough where no trough end flanges are required. Drilling for three bolt bronze or flanged ball bearing is standard.

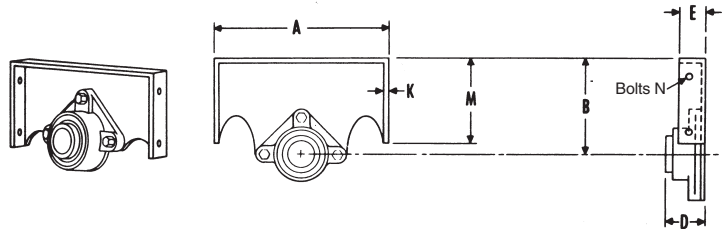

Conveyor Diameter	Shaft Diameter	Part Number	A	B	D			E	K	M	N	Weight
					Friction Bearing	Ball Bearing	Roller Bearing					
4	1	4TDI2-*	5	3 ⁵ / ₁₆	2 ¹ / ₁₆	1 ⁵ / ₁₆	2	1/4	3 ⁵ / ₁₆	3/8	2	
6	1 1/2	6TDI3-*	7	4 1/2	3 ³ / ₁₆	2 ¹ / ₁₆	3 1/16	2	1/4	4 1/2	3/8	3
9	1 1/2	9TDI3-*	10	6 1/8	3 1/4	2 ¹ / ₁₆	3 1/16	2	1/4	6 1/8	3/8	5
	2	9TDI4-*	10	6 1/8	4 1/4	2 1/2	3 3/16	2	1/4	6 1/8	3/8	5
10	1 1/2	10TDI3-*	11	6 3/8	3 3/4	2 ¹ / ₁₆	3 1/16	2	1/4	6 3/8	3/8	6
	2	10TDI4-*	11	6 3/8	4 1/4	2 1/2	3 3/16	2	1/4	6 3/8	3/8	6
12	2	12TDI4-*	13	7 3/4	4 1/4	2 ¹ / ₁₆	3 3/8	2	1/4	7 3/4	1/2	12
	2 1/16	12TDI5-*	13	7 3/4	5 1/4	2 ¹ / ₁₆	4 7/16	2	1/4	7 3/4	1/2	12
	3	12TDI6-*	13	7 3/4	6 1/4	3 3/4	4 15/16	2	1/4	7 3/4	1/2	12
14	2 1/16	14TDI5-*	15	9 1/4	5 5/16	2 ¹ / ₁₆	4 7/16	2	1/4	9 1/4	5/8	16
	3	14TDI6-*	15	9 1/4	6 5/16	3 3/4	4 15/16	2	1/4	0.9 1/4	5/8	16
16	3	16TDI6-*	17	10 5/8	6 5/16	3 3/16	5	2	5/16	10 5/8	5/8	25
	3	18TDI6-*	19	12 1/8	6 3/8	3 3/16	5	2	3/8	12 1/8	5/8	32
18	3 3/16	18TDI7-*	19	12 3/8	7 3/8	4 1/16	5 5/16	2	3/8	12 1/8	5/8	32
	3	20TDI16-*	21	13 1/2	6 3/8	3 3/8	5 5/16	2	3/8	13 1/2	5/8	50
20	3 3/16	20TDI7-*	21	13 1/2	7 3/8	4 3/8	5 5/8	2	3/8	13 1/2	5/8	50
	3 3/16	24TDI7-*	25	16 1/2	7 3/8	4 3/8	5 5/8	2	3/8	16 1/2	5/8	76

-*BB Ball / Bronze Bearing
-P Less Bearing

Trough Ends

Outside

Outside tubular trough ends less feet are used to support end bearings on tubular trough where no foot or support is required. Drilling for bronze or flanged ball bearing is standard.

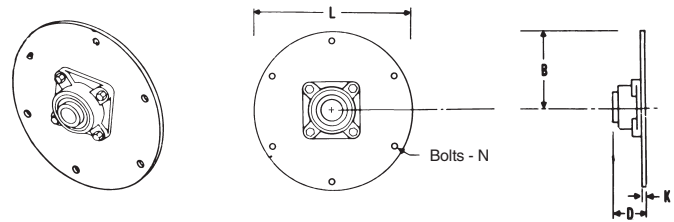

Conveyor Diameter	Shaft Diameter	Part Number	B	D			K	L	N	Weight
				Friction Bearing	Ball Bearing	Roller Bearing				
4	1	4CHTE2-*	4	2 ³ / ₁₆	1 ⁵ / ₁₆		¼	8	¾	2
6	1½	6CHTE3-*	5 ¹ / ₁₆	3 ³ / ₁₆	2 ³ / ₁₆	3 ¹ / ₁₆	¼	10 ⁵ / ₁₆	¾	3
9	1½	9CHTE3-*	6 ⁵ / ₁₆	3¼	2 ³ / ₁₆	3 ¹ / ₁₆	¼	13¼	¾	6
	2	9CHTE4-*	6 ⁵ / ₁₆	4¼	2½	3 ³ / ₁₆	¼	13¼	¾	6
10	1½	10CHTE3-*	7 ⁷ / ₁₆	3¼	2 ³ / ₁₆	3 ¹ / ₁₆	¼	14¾	¾	7
	2	10CHTE4-*	7 ⁷ / ₁₆	4¼	2½	3 ³ / ₁₆	¼	14¾	¾	7
12	2	12CHTE4-*	8 ⁸ / ₁₆	4¼	2 ³ / ₁₆	3 ³ / ₈	¼	16¼	½	13
	2 ¹ / ₁₆	12CHTE5-*	8 ⁸ / ₁₆	5¼	2 ¹ / ₁₆	4 ⁷ / ₁₆	¼	16 ¹ / ₁₆	½	13
	3	12CHTE6-*	8 ⁸ / ₁₆	6¼	3 ³ / ₈	4 ¹ / ₁₆	¼	16 ¹ / ₁₆	½	13
14	2 ¹ / ₁₆	14CHTE5-*	9 ⁹ / ₁₆	5 ⁵ / ₁₆	2 ¹ / ₁₆	4 ⁷ / ₁₆	¼	18¼	½	19
	3	14CHTE6-*	9 ⁹ / ₁₆	6 ⁵ / ₁₆	3¼	4 ¹ / ₁₆	¼	18¼	½	19
16	3	16CHTE6-*	10 ¹⁰ / ₁₆	6 ⁵ / ₁₆	3 ³ / ₁₆	5	5 ¹ / ₁₆	21¼	¾	29
	3 ³ / ₁₆	18CHTE7-*	12 ¹² / ₁₆	7 ⁷ / ₁₆	4 ¹ / ₁₆	5 ⁵ / ₁₆	¾	24¼	¾	39
18	3	18CHTE6-*	12 ¹² / ₁₆	6 ⁶ / ₁₆	3 ³ / ₁₆	5	¾	24¼	¾	39
	3 ³ / ₁₆	20CHTE6-*	13 ¹³ / ₁₆	6 ⁶ / ₁₆	3 ³ / ₈	5 ⁵ / ₁₆	¾	26 ¹ / ₁₆	¾	63
20	3	20CHTE7-*	13 ¹³ / ₁₆	7 ⁷ / ₁₆	4 ³ / ₈	5 ⁵ / ₁₆	¾	26¼	¾	63
	3 ³ / ₁₆	24CHTE7-*	15 ¹⁵ / ₁₆	7 ⁷ / ₁₆	4 ³ / ₈	5 ⁵ / ₁₆	¾	30¼	¾	87

Outside with Feet

Outside tubular trough ends with feet are used to support end bearing where trough support is required. Drilling for bronze bearing or flanged ball bearing is standard.

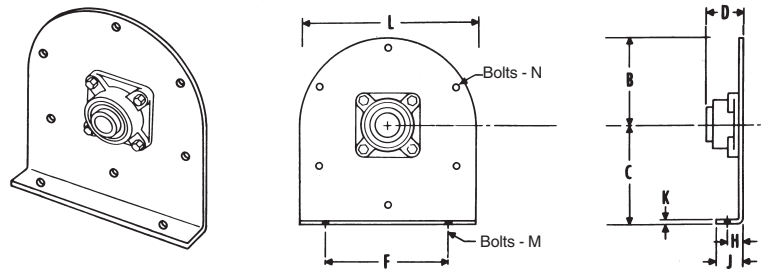

Conveyor Diameter	Shaft Diameter	Part Number	B	C	D			F	H	J	K	L	M	N	Weight
					Friction Bearing	Ball Bearing	Roller Bearing								
4	1	4CHTEF2-*	4	4 ⁵ / ₁₆	2 ³ / ₁₆	1 ⁵ / ₁₆		5¾	1	1 ⁵ / ₁₆	¼	8	¾	¾	3
6	1½	6CHTEF3-*	5 ¹ / ₁₆	5 ⁵ / ₁₆	3 ³ / ₁₆	2 ³ / ₁₆	3 ¹ / ₁₆	8 ⁸ / ₁₆	1	1¼	¼	10 ⁵ / ₁₆	¾	¾	5
9	1½	9CHTEF3-*	6 ⁵ / ₁₆	7 ⁷ / ₁₆	3¼	2 ³ / ₁₆	3 ¹ / ₁₆	9 ⁹ / ₁₆	1½	2 ¹ / ₁₆	¼	13¼	½	¾	10
	2	9CHTEF4-*	6 ⁵ / ₁₆	7 ⁷ / ₁₆	4¼	2½	3 ³ / ₁₆	9 ⁹ / ₁₆	1½	2 ¹ / ₁₆	¼	13¼	½	¾	10
10	1½	10CHTEF3-*	7 ⁷ / ₁₆	8 ⁸ / ₁₆	3¼	2 ³ / ₁₆	3 ¹ / ₁₆	9½	1¾	2 ¹ / ₁₆	¼	14¾	½	¾	12
	2	10CHTEF4-*	7 ⁷ / ₁₆	8 ⁸ / ₁₆	4¼	2½	3 ³ / ₁₆	9½	1¾	2 ¹ / ₁₆	¼	14¾	½	¾	12
12	2	12CHTEF4-*	8 ⁸ / ₁₆	9 ⁹ / ₁₆	4¼	2 ³ / ₁₆	3 ³ / ₈	12¼	1 ⁵ / ₁₆	2¼	¼	16¼	¾	½	22
	2 ¹ / ₁₆	12CHTEF5-*	8 ⁸ / ₁₆	9 ⁹ / ₁₆	5¼	2 ¹ / ₁₆	4 ⁷ / ₁₆	12¼	1 ⁵ / ₁₆	2¼	¼	16¼	¾	½	22
	3	12CHTEF6-*	8 ⁸ / ₁₆	9 ⁹ / ₁₆	6¼	3 ³ / ₈	4 ¹ / ₁₆	12¼	1 ⁵ / ₁₆	2¼	¼	16¼	¾	½	22
14	2 ¹ / ₁₆	14CHTEF5-*	9 ⁹ / ₁₆	10 ¹⁰ / ₁₆	5 ⁵ / ₁₆	2 ¹ / ₁₆	4 ⁷ / ₁₆	13½	1 ⁵ / ₁₆	2 ¹ / ₁₆	¼	18¼	¾	½	24
	3	14CHTEF6-*	9 ⁹ / ₁₆	10 ¹⁰ / ₁₆	6 ⁵ / ₁₆	3¼	4 ¹ / ₁₆	13½	1 ⁵ / ₁₆	2 ¹ / ₁₆	¼	18¼	¾	½	24
16	3	16CHTEF6-*	10 ¹⁰ / ₁₆	12	6 ⁵ / ₁₆	3 ³ / ₁₆	5	14 ¹ / ₁₆	2	3¼	5 ¹ / ₁₆	21¼	¾	¾	44
	3 ³ / ₁₆	18CHTEF6-*	12 ¹² / ₁₆	13 ¹³ / ₁₆	6 ⁶ / ₁₆	3 ³ / ₁₆	5	16	2	3¼	¾	24¼	¾	¾	56
18	3	18CHTEF7-*	12 ¹² / ₁₆	13 ¹³ / ₁₆	7 ⁷ / ₁₆	4 ¹ / ₁₆	5 ⁵ / ₁₆	16	2	3¼	¾	24¼	¾	¾	56
	3 ³ / ₁₆	20CHTEF6-*	13 ¹³ / ₁₆	15	6 ⁶ / ₁₆	3 ³ / ₈	5 ⁵ / ₁₆	19¼	2¼	3 ³ / ₈	¾	26¼	¾	¾	92
20	3	20CHTEF7-*	13 ¹³ / ₁₆	15	7 ⁷ / ₁₆	4 ³ / ₈	5 ⁵ / ₁₆	19¼	2¼	3¼	¾	26¼	¾	¾	92
	3 ³ / ₁₆	24CHTEF7-*	15 ¹⁵ / ₁₆	18 ¹⁸ / ₁₆	7 ⁷ / ₁₆	4 ³ / ₈	5 ⁵ / ₁₆	20	2½	4 ³ / ₈	¾	30¼	¾	¾	134

-*BB Ball / Bronze Bearing
-*RB Roller Bearing

For Bolt Pattern see Page 44

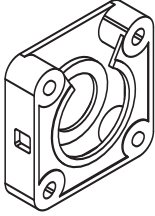
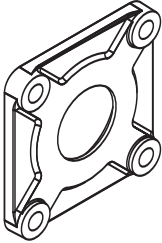
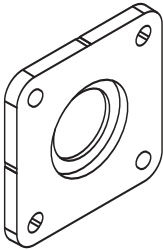
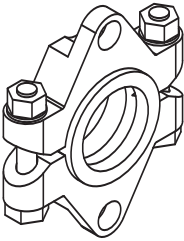
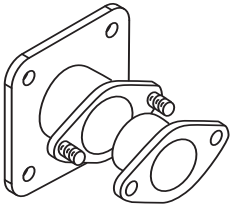
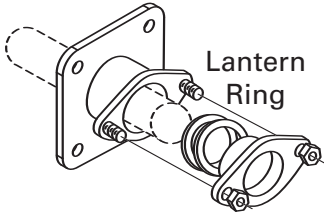
<p>WASTE PACK SEAL</p>		<p>Waste pack seals can be furnished with waste packing or in combination with lip seal. This type seal is normally installed between the trough end and bearing, but may be used separately on pedestal type trough ends. An opening is provided at top for repacking without removing seal from trough end. Can be used with flanged ball, roller or other standard 4-bolt bearings.</p>
<p>PRODUCT DROP OUT SEAL</p>		<p>This flange type dust seal is designed for insertion between trough end and flanged ball bearing. The cast iron housing is open on all four sides for exit of material that might work past seal or lubricant from bearing.</p>
<p>PLATE SEAL</p>		<p>Plate seals are the most common and economical seal. It is normally furnished with a lip seal. This type seal is normally installed between the trough end and bearing, but may be used separately on pedestal type trough ends. Can be used with flanged ball, roller or other standard 4-bolt bearings.</p>
<p>SPLIT GLAND SEAL</p>		<p>Split gland compression type seals provide for easy replacement and adjustment of packing pressure on the shaft without removal of the conveyor. These seals can be installed inside or outside the end plates.</p>
<p>COMPRESSION TYPE PACKING GLAND SEAL</p>		<p>Flanged packing gland seals consist of an external housing and an internal gland which is forced into the housing to compress the packing. This is the most positive type shaft seal and may be used where minor pressure requirements are desired.</p>
<p>AIR PURGED SEAL</p>		<p>Air purge shaft seals are arranged for attaching to standard or special trough ends. A constant air pressure is maintained to prevent material from escaping from the trough along the shaft. The air purge seal is desirable for sealing highly abrasive materials.</p>

Shaft Seals

Compression Type Packing Gland Seal

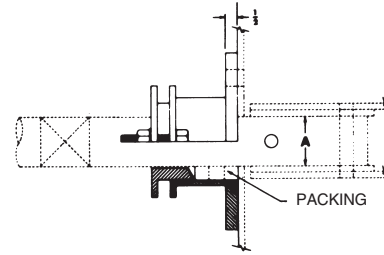
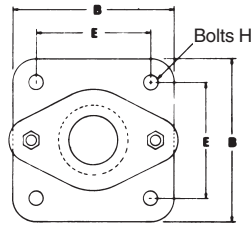

A Shaft Diameter	Part Number	B	E	H Bolts	Weight
1½	PGC3	5	4	½	14
2	PGC4	7½	5½	⅝	18
2¼	PGC5	7¾	5¾	⅝	21
3	PGC6	8½	6	¾	27
3⅞	PGC7	9¼	6¾	¾	30

*Braided rope graphite packing is standard. Other types available on request.

Flanged gland seals consist of an external housing and an internal gland which is forced into the housing to compress the packing. This is the most positive type shaft seal and may be used where pressure requirements are desired.

Split Gland Seal

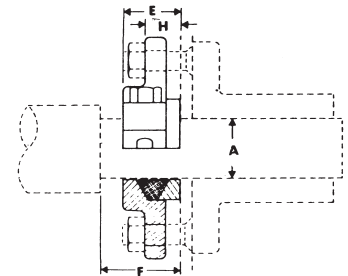
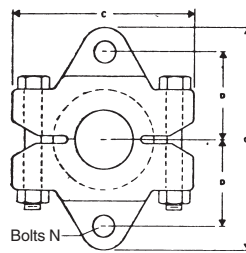

A Shaft Diameter	Part Number	C	D	E	F	G	H	N Bolts	Weight
1½	CSS3	4¾	2⅞	1⅞	2½	5⅞	⅞	½	5
2	CSS4	6¼	2⅝	1½	2½	6½	⅞	½	10
2¼	CSS5	6¾	3⅞	1¾	3¼	7¾	1	¾	15
3	CSS6	7½	3⅞	1¾	3¼	8¾	1	¾	22
3⅞	CSS7	8¾	4¾	2½	3¾	10¼	1¼	¾	30

Split gland compression type seals provide for easy replacement and adjustment of packing pressure on the shaft without removal of the conveyor. These seals are normally installed inside the end plates.

Flanged Product Drop-Out Seal

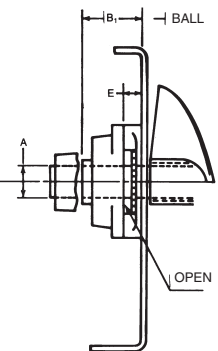
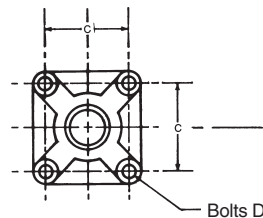

Dimensions in inches and average weight in pounds

A Shaft Diameter	Part Number	Weight	B ₁	C	E	D Bolts
1	CSFP2	1.75	2⅞	2¾	1⅞	⅞
1½	CSFP3	3.4	2 ⁵⁷ / ₆₄	4	⅞	½
2	CSFP4	5.3	3⅞	5½	⅞	¾
2¼	CSFP5	5.8	3⅞	5½	⅞	¾
3	CSFP6	7.2	4¾	6	⅞	¾
3⅞	CSFP7	—	4 ³¹ / ₃₂	6¾	1	¾

This flange type dust seal is designed for insertion between trough end and flanged bearing. The cast iron housing is open on all four sides for exit of material that might work past seal or lubricant from bearing.

Waste Pack Seal

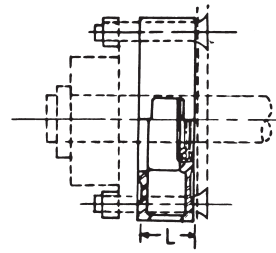
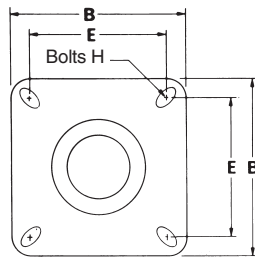

With Lip Seal

A Shaft	Part Number	B	L	E		H Bolts		Weight
				(-B)	(-R)	(-B)	(-R)	
1½	CSW3	5½	1¾	4	4½	½	½	6
2	CSW4	6½	1¾	5½	4¾	⅝	½	8
2⅞	CSW5	7¾	1¾	5½	5½	⅝	⅝	10
3	CSW6	7¾	1¾	6	6	¾	¾	13
3⅞	CSW7	9¼	2¼	6¾	7	¾	¾	16

Waste pack seals are furnished with waste packing in combination with lip seal. This type seal is normally installed between the trough end and bearing, but may be used separately on pedestal type trough ends. An opening is provided at top for repacking without removing seal from trough end.

Plate Seal

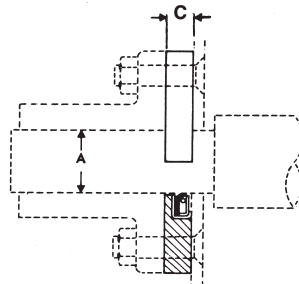
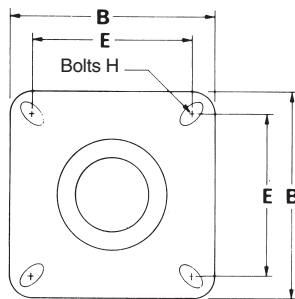
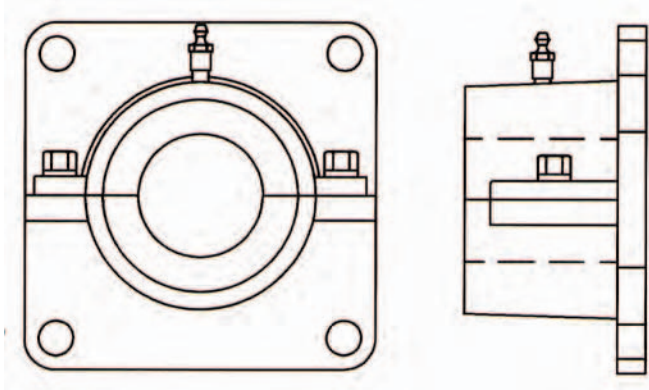

Plate seals are the most common and economical seal. They are furnished with a lip seal. This type seal is normally installed between the trough end and bearing, but may be used separately on pedestal type trough ends. Slotted mounting holes allow use with both ball and roller flanged bearings.

A Shaft Diameter	Part Number	B	C	E		H Bolts		Weight
				(-B)	(-R)	(-B)	(-R)	
1½	CSP3	5½	½	4	4½	½	½	2
2	CSP4	6½	½	5½	4¾	⅝	½	3
2⅞	CSP5	7¾	½	5½	5½	⅝	⅝	4
3	CSP6	7¾	½	6	6	¾	¾	5
3⅞	CSP7	9¼	¾	6¾	7	¾	¾	8

KEEP THE HOUSING REPLACE THE INSERT.



Split Bearing Housings will help cut down on a plant's repair parts inventory, as well as the cost of the bearing. The rugged cast iron housing is not subject to wear, only the Style 220 Hanger bearing insert needs to be replaced.

The housings match CEMA standard ball bearing bolt pattern, so they can be used with most seals.

Split bearing housings are stocked in all our stocking facilities. Contact the factory for more information.

TROUGH END BEARING HOUSINGS

Split Bearing Housings utilize Style 220 Hanger Bearings.

FLANGE UNITS	Mounted on trough end plate.		Ball Bearing Flange Unit
			Roller Bearing Flange Unit
			Bronze Sleeve Bearing Flange Unit
PILLOW BLOCKS	Mounted on pedestal of outboard bearing trough end.		Ball Bearing Pillow Block
			Roller Bearing Pillow Block

Bronze Flange Unit

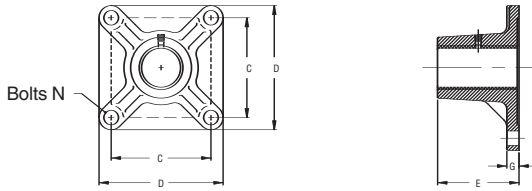

Bore	Part Number	C	D	E	G	N
1	TEB2BR	2 $\frac{3}{4}$	3 $\frac{3}{4}$	2	$\frac{7}{16}$	$\frac{3}{8}$
1 $\frac{1}{2}$	TEB3BR	4	5 $\frac{1}{2}$	3 $\frac{1}{4}$	$\frac{3}{4}$	$\frac{1}{2}$
2	TEB4BR	5 $\frac{1}{2}$	6 $\frac{1}{2}$	4 $\frac{3}{16}$	$\frac{7}{8}$	$\frac{5}{8}$
2 $\frac{1}{16}$	TEB5BR	5 $\frac{1}{2}$	7 $\frac{1}{2}$	4 $\frac{15}{16}$	1	$\frac{5}{8}$
3	TEB6BR	6	7 $\frac{3}{4}$	5 $\frac{11}{16}$	1 $\frac{1}{8}$	$\frac{3}{4}$
3 $\frac{1}{16}$	TEB7BR	6 $\frac{3}{4}$	9 $\frac{1}{4}$	6 $\frac{1}{4}$	1 $\frac{1}{4}$	$\frac{3}{4}$

Ball Bearing Discharge Unit

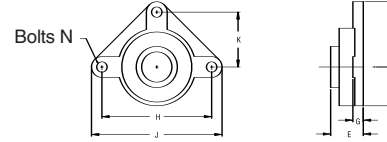

Bore	Part Number	E	G	H	J	K	L	M	N
1	TDB2BB	1 $\frac{1}{2}$	$\frac{1}{2}$	3 $\frac{3}{8}$	5 $\frac{3}{8}$	1 $\frac{15}{16}$	2 $\frac{11}{16}$	2	$\frac{3}{8}$
1 $\frac{1}{2}$	TDB3BB	2	$\frac{9}{16}$	5 $\frac{3}{8}$	7 $\frac{1}{4}$	2 $\frac{19}{16}$	3 $\frac{3}{8}$	2 $\frac{1}{2}$	$\frac{1}{2}$
2	TDB4BB	2 $\frac{1}{4}$	$\frac{5}{8}$	7 $\frac{1}{4}$	8	3 $\frac{3}{8}$	4	3	$\frac{5}{8}$
2 $\frac{1}{16}$	TDB5BB	2 $\frac{1}{2}$	$\frac{11}{16}$	8	9 $\frac{1}{8}$	4	4 $\frac{15}{16}$	3 $\frac{1}{2}$	$\frac{5}{8}$
3	TDB6BB	3 $\frac{1}{2}$	$\frac{7}{8}$	8 $\frac{1}{2}$	11	4 $\frac{1}{4}$	5 $\frac{1}{2}$	4	$\frac{3}{4}$
3 $\frac{1}{16}$	TDB7BB	4	1	9 $\frac{1}{2}$	12	4 $\frac{3}{4}$	6	4 $\frac{1}{2}$	$\frac{3}{4}$

Ball Bearing Flange Unit

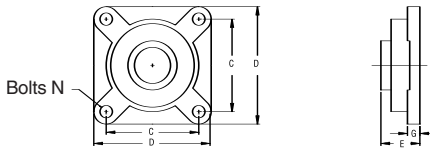

Bore	Part Number	C	D	E	G	N
1	TEB2BB	2 $\frac{3}{4}$	3 $\frac{3}{4}$	1 $\frac{1}{2}$	$\frac{1}{2}$	$\frac{3}{8}$
1 $\frac{1}{2}$	TEB3BB	4	5 $\frac{1}{2}$	1 $\frac{1}{2}$	$\frac{9}{16}$	$\frac{1}{2}$
2	TEB4BB	5 $\frac{1}{2}$	6 $\frac{1}{2}$	2 $\frac{1}{16}$	1 $\frac{1}{16}$	$\frac{5}{8}$
2 $\frac{1}{16}$	TEB5BB	5 $\frac{1}{2}$	6 $\frac{1}{2}$	2 $\frac{1}{16}$	1 $\frac{1}{16}$	$\frac{5}{8}$
3	TEB6BB	6	7 $\frac{3}{4}$	3 $\frac{1}{8}$	$\frac{7}{8}$	$\frac{3}{4}$
3 $\frac{1}{16}$	TEB7BB	6 $\frac{3}{4}$	8 $\frac{7}{16}$	3 $\frac{3}{8}$	1	$\frac{3}{4}$

Trough End Bearing Housing

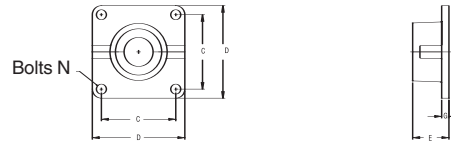

Bore	Part Number	C	D	E	G	N
1 $\frac{1}{2}$	TEBH3	4	5 $\frac{1}{4}$	2 $\frac{1}{2}$	$\frac{1}{2}$	$\frac{1}{2}$
2	TEBH4	5 $\frac{1}{2}$	6 $\frac{1}{2}$	2 $\frac{1}{2}$	$\frac{1}{2}$	$\frac{5}{8}$
2 $\frac{1}{16}$	TEBH5	5 $\frac{1}{2}$	6 $\frac{1}{8}$	3 $\frac{3}{16}$	$\frac{9}{16}$	$\frac{5}{8}$
3	TEBH6	6	7 $\frac{3}{4}$	3 $\frac{3}{8}$	$\frac{5}{8}$	$\frac{3}{4}$
3 $\frac{1}{16}$	TEBH7	7	9 $\frac{1}{4}$	4 $\frac{1}{4}$	$\frac{3}{4}$	$\frac{3}{4}$

Use #220 Type Hanger Bearings, See Page 77.

Roller Bearing Flange Unit

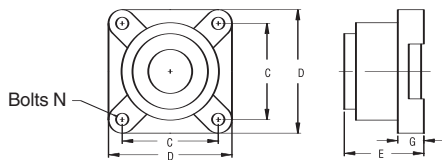

Bore	Part Number	C	D	E	G	N
1 $\frac{1}{2}$	TEB3R	4 $\frac{1}{8}$	5 $\frac{1}{8}$	3 $\frac{1}{2}$	1 $\frac{1}{16}$	$\frac{1}{2}$
2	TEB4R	4 $\frac{3}{8}$	5 $\frac{3}{8}$	3 $\frac{3}{8}$	1 $\frac{3}{16}$	$\frac{1}{2}$
2 $\frac{1}{16}$	TEB5R	5 $\frac{1}{8}$	6 $\frac{1}{8}$	4 $\frac{3}{16}$	1 $\frac{1}{2}$	$\frac{5}{8}$
3	TEB6R	6	7 $\frac{3}{4}$	4 $\frac{11}{16}$	1 $\frac{1}{8}$	$\frac{3}{4}$
3 $\frac{1}{16}$	TEB7R	7	9 $\frac{1}{4}$	5 $\frac{1}{4}$	1 $\frac{1}{8}$	$\frac{3}{4}$

Ball Bearing Pillow Block

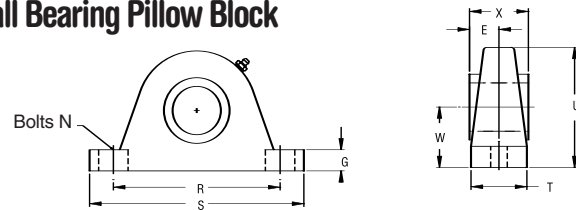

Bore	Part Number	E	G	N	R	S	T	U	W	X
1	TPB2BB	1 $\frac{3}{16}$	1 $\frac{3}{16}$	$\frac{3}{8}$	4 $\frac{1}{8}$	5 $\frac{1}{8}$	1 $\frac{1}{2}$	3 $\frac{3}{16}$	1 $\frac{1}{16}$	1 $\frac{1}{8}$
1 $\frac{1}{2}$	TPB3BB	1 $\frac{15}{16}$	1 $\frac{1}{4}$	$\frac{1}{2}$	5 $\frac{3}{8}$	6 $\frac{1}{8}$	2	4 $\frac{1}{8}$	2 $\frac{1}{4}$	1 $\frac{15}{16}$
2	TPB4BB	1 $\frac{1}{8}$	1 $\frac{3}{8}$	$\frac{5}{8}$	6 $\frac{1}{4}$	7 $\frac{3}{8}$	2 $\frac{1}{4}$	4 $\frac{3}{16}$	2 $\frac{1}{4}$	2 $\frac{3}{16}$
2 $\frac{1}{16}$	TPB5BB	1 $\frac{1}{8}$	1 $\frac{1}{8}$	$\frac{5}{8}$	7 $\frac{1}{4}$	9	2 $\frac{1}{2}$	5 $\frac{1}{2}$	2 $\frac{1}{4}$	2 $\frac{1}{16}$
3	TPB6BB	1 $\frac{15}{16}$	2 $\frac{1}{8}$	$\frac{7}{8}$	9	11 $\frac{1}{8}$	3 $\frac{1}{2}$	7 $\frac{1}{8}$	3 $\frac{1}{2}$	3 $\frac{1}{4}$
3 $\frac{1}{16}$	TPB7BB	2 $\frac{1}{4}$	2 $\frac{3}{8}$	$\frac{7}{8}$	11 $\frac{1}{8}$	13 $\frac{1}{8}$	4 $\frac{1}{2}$	8 $\frac{1}{4}$	4	3 $\frac{3}{8}$

Bronze Discharge Unit

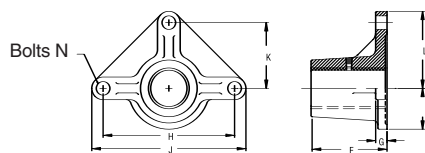

Bore	Part Number	E	G	H	J	K	L	M	N
1	TDB2BR	2	$\frac{1}{2}$	3 $\frac{3}{8}$	5 $\frac{1}{2}$	1 $\frac{15}{16}$	2 $\frac{11}{16}$	1	$\frac{3}{8}$
1 $\frac{1}{2}$	TDB3BR	3 $\frac{3}{4}$	$\frac{9}{16}$	5 $\frac{1}{2}$	7 $\frac{1}{4}$	2 $\frac{19}{16}$	3 $\frac{3}{8}$	1 $\frac{1}{4}$	$\frac{1}{2}$
2	TDB4BR	4 $\frac{3}{16}$	$\frac{5}{8}$	7 $\frac{1}{4}$	8	3 $\frac{3}{8}$	4	1 $\frac{1}{8}$	$\frac{5}{8}$
2 $\frac{1}{16}$	TDB5BR	4 $\frac{15}{16}$	$\frac{11}{16}$	8	9 $\frac{1}{8}$	4	4 $\frac{15}{16}$	1 $\frac{1}{8}$	$\frac{5}{8}$
3	TDB6BR	5 $\frac{11}{16}$	$\frac{7}{8}$	8 $\frac{1}{2}$	11	4 $\frac{1}{4}$	5 $\frac{1}{2}$	2 $\frac{1}{8}$	$\frac{3}{4}$
3 $\frac{1}{16}$	TDB7BR	6 $\frac{1}{4}$	1	9 $\frac{1}{2}$	12	4 $\frac{3}{4}$	6	2 $\frac{1}{2}$	$\frac{3}{4}$

Roller Bearing Pillow Block

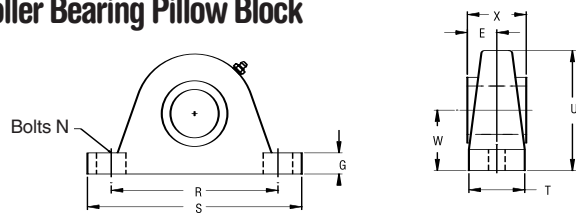

Bore	Part Number	E	G	N	R	S	T	U	W
1 $\frac{1}{2}$	TPB3R	3 $\frac{3}{8}$	1 $\frac{1}{4}$	$\frac{1}{2}$	6 $\frac{1}{4}$	7 $\frac{1}{8}$	2 $\frac{3}{8}$	4 $\frac{1}{4}$	2 $\frac{1}{2}$
2	TPB4R	3 $\frac{1}{2}$	1 $\frac{3}{8}$	$\frac{5}{8}$	7	8 $\frac{3}{8}$	2 $\frac{1}{2}$	4 $\frac{1}{2}$	2 $\frac{1}{4}$
2 $\frac{1}{16}$	TPB5R	4	1 $\frac{1}{8}$	$\frac{5}{8}$	8 $\frac{1}{2}$	10 $\frac{1}{2}$	2 $\frac{1}{8}$	5 $\frac{1}{2}$	2 $\frac{3}{4}$
3	TPB6R	4 $\frac{1}{2}$	1 $\frac{1}{8}$	$\frac{3}{4}$	9 $\frac{1}{2}$	12	3 $\frac{1}{8}$	6 $\frac{1}{4}$	3 $\frac{3}{8}$
3 $\frac{1}{16}$	TPB7R	5	2 $\frac{1}{4}$	$\frac{7}{8}$	11	14	3 $\frac{3}{8}$	7 $\frac{1}{2}$	3 $\frac{3}{4}$

Thrust Bearings

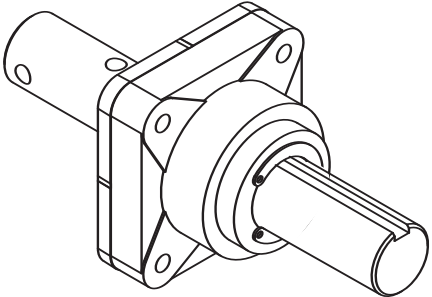
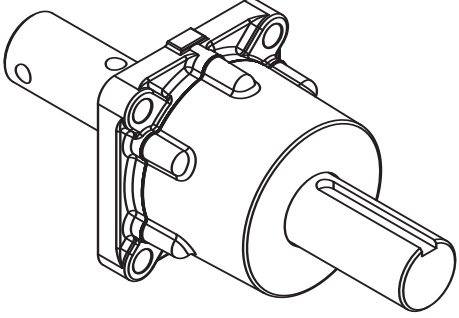
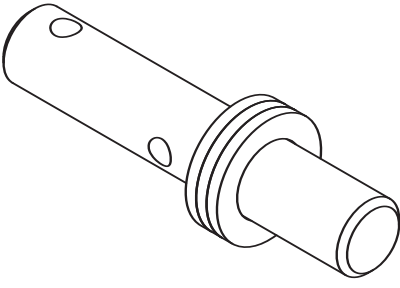
<p>TYPE E THRUST BEARINGS</p>	 A technical drawing of a Type E thrust bearing. It features a cylindrical shaft with a central hole, mounted on a rectangular housing. The housing has four mounting holes on its side and a circular flange at the end of the shaft.	<p>Most common and economical thrust unit when a screw conveyor type drive is not being used.</p>
<p>TYPE H THRUST BEARINGS</p>	 A technical drawing of a Type H thrust bearing. It consists of a cylindrical shaft with a central hole, mounted on a housing that has a large circular flange. The housing also has a smaller cylindrical protrusion on its side.	<p>For heavy duty thrust requirements.</p>
<p>BRONZE WASHER</p>	 A technical drawing of a bronze washer. It is a cylindrical component with a central hole and a slightly wider, flanged section at one end.	<p>Light duty applications only. Used inside the trough and when screw used in compression.</p>

Type E Thrust Assembly

Type E roller thrust bearings are designed to carry thrust in both directions and carry radial load under normal conditions. This double roller bearing is furnished with a lip type seal plate and either drive or tail shaft whichever is applicable to conveyor design.

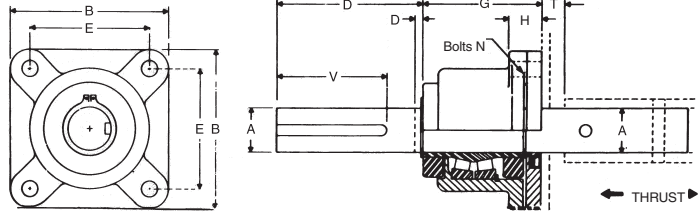

A Shaft Diameter	Part Number		B	D		E	G	H	N	T	V	Weight	
	Drive Shaft	End Shaft		Drive Shaft	End Shaft							Drive Shaft	End Shaft
1½	CT3D	CT3E	5⅝	4¾	¾	4⅞	4	1⅞	½	1¼	4	22	20
2	CT4D	CT4E	5⅝	5	¾	4⅞	4⅞	1⅞	½	1¼	4½	32	29
2⅞	CT5D	CT5E	6⅞	5½	¾	5⅞	4⅞	2	¾	1⅞	5	50	44
3	CT6D	CT6E	7¾	6½	¾	6	5⅞	2⅞	¾	1⅞	6	73	60
3⅞	CT7D	CT7E	9¼	7½	¾	7	6	2⅞	¾	2⅞	7	111	88

Heavy Duty RB End Thrust Bearings

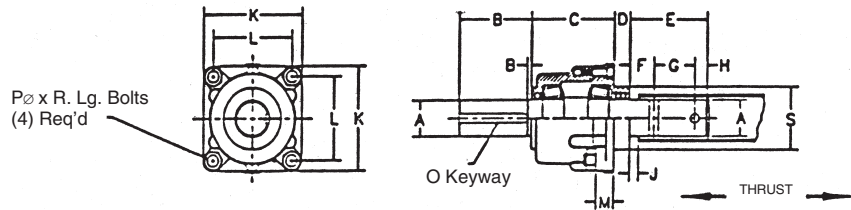

Dimensions in inches and average weight in pounds

A Shaft Dia.	With Drive Shaft		With Tail Shaft		B		C	D	E	F	G	H	J	K	L	M	O Keyway	P	R	S
	Part No.	Weight	Part No.	Weight	Drive Shaft	End Shaft														
1½	CTH3D	60	CTH3E	52	4½	¼	6¾	1⅞	4⅞	1	3	⅞	⅞	7¼	5¾	1⅞	¾ × 4¼	¾	2½	4¾
2	CTH4D	65	CTH4E	56	4½	¼	6¾	1⅞	4⅞	1	3	⅞	⅞	7¼	5¾	1⅞	¾ × 4¼	¾	2½	4¾
2⅞	CTH5D	80	CTH5E	66	5⅞	⅝	6¼	1¼	5⅞	1½	3	⅞	⅞	8	6¼	1½	¾ × 5¼	¾	3	5½
3	CTH6D	145	CTH6E	119	6⅞	¼	8¼	1½	5⅞	1⅞	3	1	⅞	10	8	1¾	¾ × 5¼	1	3½	6
3⅞	CTH7D	170	CTH7E	140	7⅞	⅝	8¼	1½	7⅞	2⅞	4	1¼	⅞	10	8	1¾	¾ × 6¼	1	3½	6

Other shaft sizes available are 3⅞", 4⅞" & 4⅞". Please consult factory.

Thrust Washers

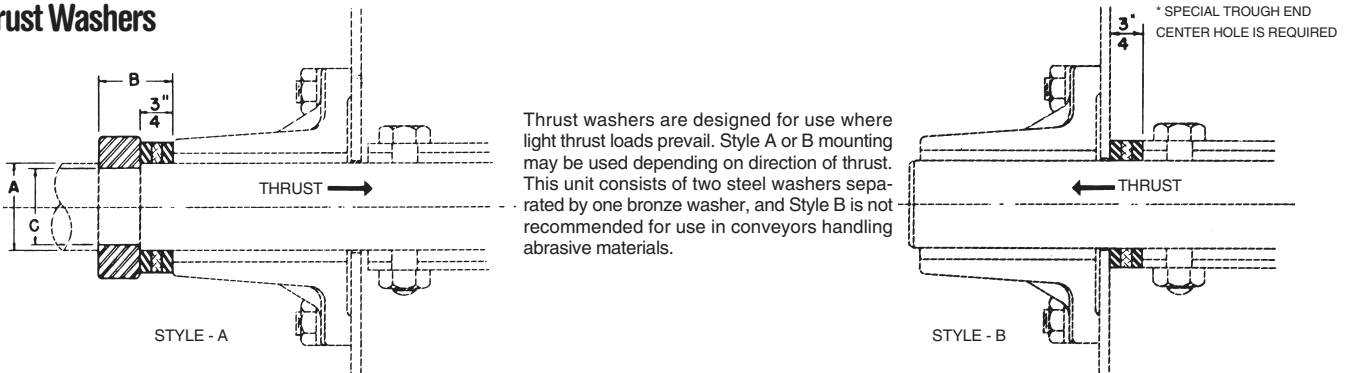

Thrust washers are designed for use where light thrust loads prevail. Style A or B mounting may be used depending on direction of thrust. This unit consists of two steel washers separated by one bronze washer, and Style B is not recommended for use in conveyors handling abrasive materials.

A Size Shaft	Washers & Collar Style A		Washer Set Style B		B	C
	Part No.	Weight	Part No.	Weight		
1½	CTCW3	2.4	CTW3	1	1¼	1¼
2	CTCW4	2.8	CTW4	1.25	1⅞	1¾
2⅞	CTCW5	3.9	CTW5	1.5	1⅞	2⅞
3	CTCW6	4.6	CTW6	2	1½	2¾
3⅞	CTCW7	6.1	CTW7	3	1⅞	3¼

Conveyor Trough

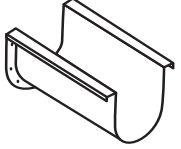
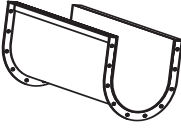
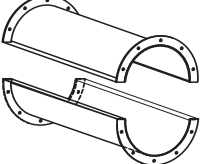
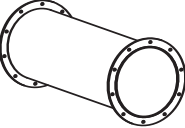
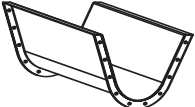
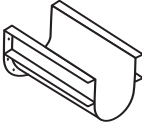
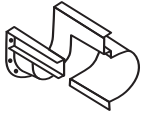
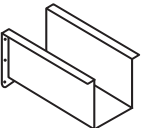
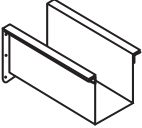
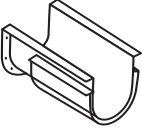
<p>FORMED FLANGE U-TROUGH</p>		<p>Commonly used economical trough. One piece construction. Standard lengths in stock.</p>
<p>ANGLE FLANGE U-TROUGH</p>		<p>Rigid construction. Standard lengths in stock.</p>
<p>FORMED FLANGE TUBULAR TROUGH</p>		<p>Loadable to full cross section for feeder applications. Minimizes fall back in inclined applications. Easily taken apart for maintenance. Can be gasketed for dust tight enclosure. Hanger pockets required for use with standard hangers.</p>
<p>SOLID TUBULAR TROUGH</p>		<p>One piece construction for totally enclosed or inclined applications. Hanger pockets required for use with standard hangers.</p>
<p>FLARED TROUGH</p>		<p>Used where materials tend to bridge or when flared inlets are needed.</p>
<p>CHANNEL TROUGH</p>		<p>Adds structural support for longer than standard spans.</p>
<p>DROP BOTTOM TROUGH</p>		<p>Used when complete material clean-out is critical. Can be furnished with hinges either side and bolts or clamps opposite side.</p>
<p>FORMED FLANGE RECTANGULAR TROUGH</p>		<p>Material being conveyed forms its own trough thereby reducing trough wear. One piece construction.</p>
<p>ANGLE FLANGE RECTANGULAR TROUGH</p>		<p>The same as formed flange rectangular except top flanges are made from structural angle.</p>
<p>JACKETED TROUGH</p>		<p>Jacket allows heating or cooling of material being conveyed.</p>

Standard conveyor troughs have a U-shaped steel body with angle iron top flanges or formed top flanges and jig drilled end flanges.

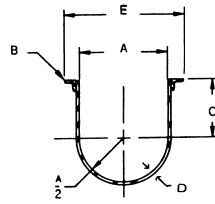
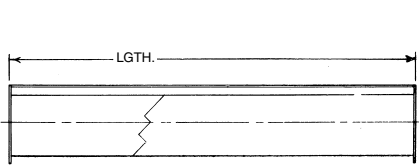

Angle Flange

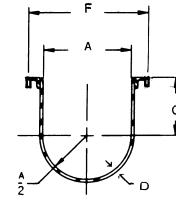

Formed Flange

Conveyor Diameter	D	Angle Flanged	Angle Flanged Trough				Formed Flanged Trough ▲				A	B	C	E	F	
			Weight		Weight		Weight		Weight							
			10' Length	5' Length	12' Length	6' Length	Part Number	10' Length	5' Length	12' Length						6' Length
Trough Thick.	Part Number	10' Length	5' Length	12' Length	6' Length	Part Number	10' Length	5' Length	12' Length	6' Length	A	B	C	E	F	
4	★ 14 GA.	4CTA14	60	33	—	—	4CTF14	50	28	—	—	5	1¼	3%	7 ¹¹ / ₁₆	7 ¹¹ / ₁₆
4	12	4CTA12	78	42	—	—	4CTF12	70	38	—	—				7¾	8
6	★ 14 GA.	6CTA14	78	49	—	—	6CTF14	67	38	—	—	7	1¼	4½	9 ¹¹ / ₁₆	9 ¹¹ / ₁₆
6	12	6CTA12	101	60	—	—	6CTF12	91	50	—	—				9¾	10
6	10	6CTA10	123	73	—	—	6CTF10	117	64	—	—				9¾	10
6	¾	6CTA7	164	86	—	—	6CTF7	150	79	—	—				9¾	9¾
9	★ 14 GA.	9CTA14	127	73	—	—	9CTF14	99	59	—	—	10	1½	6%	13 ³ / ₁₆	13 ³ / ₁₆
9	12	9CTA12	156	87	—	—	9CTF12	132	75	—	—				13¾	13½
9	10	9CTA10	176	102	—	—	9CTF10	164	91	—	—				13 ³ / ₁₆	13½
9	¾	9CTA7	230	124	—	—	9CTF7	214	116	—	—				13¾	13¾
9	¼	9CTA3	286	152	—	—	9CTF3	276	147	—	—				13½	13½
10	★ 14 GA.	10CTA14	133	76	—	—	10CTF14	105	62	—	—	11	1½	6%	14 ⁴ / ₁₆	14 ⁴ / ₁₆
10	12	10CTA12	164	92	—	—	10CTF12	140	80	—	—				14¼	14½
10	10	10CTA10	178	102	—	—	10CTF10	167	91	—	—				14 ⁴ / ₁₆	14½
10	¾	10CTA7	233	131	—	—	10CTF7	217	123	—	—				14¾	14¾
10	¼	10CTA3	306	163	—	—	10CTF3	296	158	—	—				14½	14½
12	★ 12 GA.	12CTA12	197	113	236	135	12CTF12	164	95	197	114	13	2	7%	17¼	17½
12	10	12CTA10	234	133	281	160	12CTF10	187	117	224	140				17 ¹¹ / ₁₆	17½
12	¾	12CTA7	294	164	353	197	12CTF7	272	150	326	180				17¾	17¾
12	¼	12CTA3	372	203	446	244	12CTF3	357	194	428	233				17½	17½
14	★ 12 GA.	14CTA12	214	121	257	145	14CTF12	183	102	219	122	15	2	9¼	19¼	19½
14	10	14CTA10	258	143	309	172	14CTF10	207	127	248	152				19 ⁹ / ₁₆	19½
14	¾	14CTA7	328	180	394	216	14CTF7	304	168	365	202				19¾	19¾
14	¼	14CTA3	418	224	501	269	14CTF3	403	215	483	258				19½	19½
16	★ 12 GA.	16CTA12	238	133	285	160	16CTF12	206	107	247	128	17	2	10%	21¼	21½
16	10	16CTA10	288	159	345	191	16CTF10	234	144	281	173				21 ¹ / ₁₆	21½
16	¾	16CTA7	368	200	442	240	16CTF7	345	188	414	226				21¾	21¾
16	¼	16CTA3	471	243	565	291	16CTF3	455	228	546	273				21½	21½
18	★ 12 GA.	18CTA12	252	159	302	191	18CTF12	240	133	288	160	19	2½	12%	24¼	24½
18	10	18CTA10	353	170	423	204	18CTF10	269	165	323	198				24 ⁴ / ₁₆	24½
18	¾	18CTA7	444	243	533	291	18CTF7	394	217	473	260				24¾	24¾
18	¼	18CTA3	559	298	671	358	18CTF3	520	275	624	330				24½	24½
20	★ 10 GA.	20CTA10	383	228	460	274	20CTF10	296	190	355	228	21	2½	13½	26 ¹ / ₁₆	26½
20	¾	20CTA7	484	271	581	325	20CTF7	434	247	521	296				26¾	26¾
20	¼	20CTA3	612	334	734	401	20CTF3	573	315	687	378				26½	26½
24	★ 10 GA.	24CTA10	443	255	531	306	24CTF10	384	227	461	272	25	2½	16½	30 ¹ / ₁₆	30½
24	¾	24CTA7	563	319	676	383	24CTF7	514	293	617	352				30¾	30¾
24	¼	24CTA3	717	363	860	435	24CTF3	678	339	813	406				30½	30½

★ Standard Gauge
Bolt Patterns see Page 43

All troughs available in other materials such as stainless, aluminum, abrasion resistant, etc.

▲ Double formed flange standard on all sizes 10 ga. and below.

Tubular Trough

Tubular conveyor troughs are inherently dust and weather-tight, and may be loaded to a full cross section. Conveyors with tubular troughs are rigid and are highly suitable for conveying material on an incline. Three types shown are available.

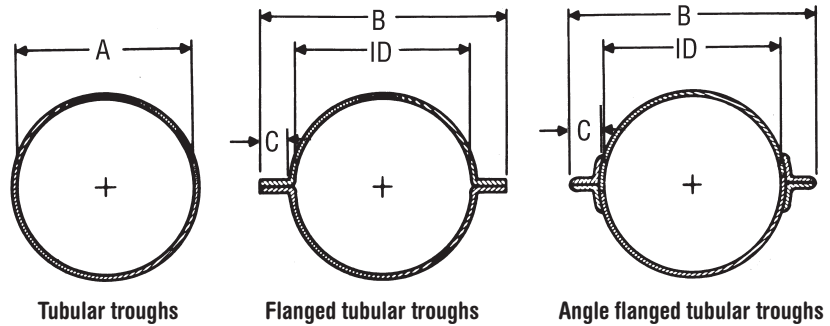

Conveyor Diameter	Trough Thickness	Tubular Trough				Formed Flange		Angle Flange		A	B	C
		Part Number	Weight		Part Number	Weight 10'	Part Number	Weight 10'				
			10' Length	5' Length								
4	★ 14 GA.	4CHT14	60	31	4CHT14-F	53	4CHT14-A	89	5	7 ⁷ / ₁₆	1	
4	12	4CHT12			4CHT12-F	74	4CHT12-A	106		7 ⁷ / ₁₆		
6	★ 14 GA.	6CHT14	62	33	6CHT14-F	75	6CHT14-A	122	7	9 ¹ / ₁₆	1 ¹ / ₄	
6	12	6CHT12	85	44	6CHT12-F	103	6CHT12-A	145		9 ⁹ / ₁₆		
6	10	6CHT10	109	56	6CHT10-F	133	6CHT10-A	187		9 ⁹ / ₁₆		
6	3/16	6CHT7	145	74	6CHT7-F	168	6CHT7-A	205		9 ⁹ / ₁₆		
9	★ 14 GA.	9CHT14	89	47	9CHT14-F	104	9CHT14-A	148	10	12 ¹ / ₁₆	1 ¹ / ₄	
9	12	9CHT12	122	64	9CHT12-F	143	9CHT12-A	181		12 ¹ / ₁₆		
9	10	9CHT10	155	80	9CHT10-F	182	9CHT10-A	214		12 ¹ / ₁₆		
9	3/16	9CHT7	208	107	9CHT7-F	245	9CHT7-A	267		12 ¹ / ₁₆		
9	1/4	9CHT3	275	140	9CHT3-F	324	9CHT3-A	334		13		
10	★ 14 GA.	10CHT14	97	52	10CHT14-F	112	10CHT14-A	156	11	13 ¹ / ₁₆	1 ¹ / ₄	
10	12	10CHT12	133	70	10CHT12-F	154	10CHT12-A	192		13 ¹ / ₁₆		
10	10	10CHT10	169	88	10CHT10-F	196	10CHT10-A	228		13 ¹ / ₁₆		
10	3/16	10CHT7	227	117	10CHT7-F	264	10CHT7-A	286		13 ¹ / ₁₆		
10	1/4	10CHT3	301	154	10CHT3-F	350	10CHT3-A	360		14		
12	★ 12 GA.	12CHT12	163	88	12CHT12-F	193	12CHT12-A	235	13	16 ¹ / ₁₆	1 ¹ / ₂	
12	10	12CHT10	208	111	12CHT10-F	247	12CHT10-A	280		16 ¹ / ₁₆		
12	3/16	12CHT7	275	144	12CHT7-F	328	12CHT7-A	347		16 ¹ / ₁₆		
12	1/4	12CHT3	362	188	12CHT3-F	432	12CHT3-A	434		16 ¹ / ₂		
14	★ 12 GA.	14CHT12	187	101	14CHT12-F	217	14CHT12-A	259	15	18 ¹ / ₁₆	1 ¹ / ₂	
14	10	14CHT10	236	126	14CHT10-F	275	14CHT10-A	308		18 ¹ / ₁₆		
14	3/16	14CHT7	316	166	14CHT7-F	369	14CHT7-A	388		18 ¹ / ₁₆		
14	1/4	14CHT3	416	216	14CHT3-F	486	14CHT3-A	488		18 ¹ / ₂		
16	★ 12 GA.	16CHT12	212	114	16CHT12-F	242	16CHT12-A	310	17	21 ¹ / ₁₆	2	
16	10	16CHT10	268	142	16CHT10-F	307	16CHT10-A	366		21 ¹ / ₁₆		
16	3/16	16CHT7	358	187	16CHT7-F	411	16CHT7-A	456		21 ¹ / ₁₆		
16	1/4	16CHT3	472	244	16CHT3-F	542	16CHT3-A	570		21 ¹ / ₂		
18	★ 12 GA.	18CHT12	242	133	18CHT12-F	280	18CHT12-A	340	19	23 ¹ / ₄	2	
18	10	18CHT10	304	164	18CHT10-F	352	18CHT10-A	402		23 ³ / ₁₆		
18	3/16	18CHT7	405	214	18CHT7-F	471	18CHT7-A	503		23 ³ / ₁₆		
18	1/4	18CHT3	533	278	18CHT3-F	621	18CHT3-A	631		23 ¹ / ₂		
20	★ 10 GA.	20CHT10	335	188	20CHT10-F	381	20CHT10-A	433	21	25 ⁵ / ₁₆	2	
20	3/16	20CHT7	446	237	20CHT7-F	510	20CHT7-A	544		25 ⁵ / ₁₆		
20	1/4	20CHT3	586	307	20CHT3-F	671	20CHT3-A	684		25 ¹ / ₂		
24	★ 10 GA.	24CHT10	399	215	24CHT10-F	445	24CHT10-A	497	25	29 ⁹ / ₁₆	2	
24	3/16	24CHT7	531	281	24CHT7-F	594	24CHT7-A	629		29 ⁹ / ₁₆		
24	1/4	24CHT3	699	365	24CHT3-F	784	24CHT3-A	797		29 ¹ / ₂		

★ Standard Gauge
For Bolt Patterns See Page 44

Flared troughs are used primarily to convey materials which are not free-flowing or which have a tendency to stick to the trough.

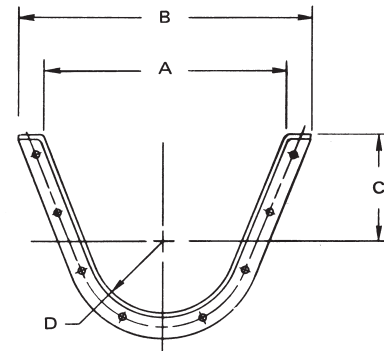
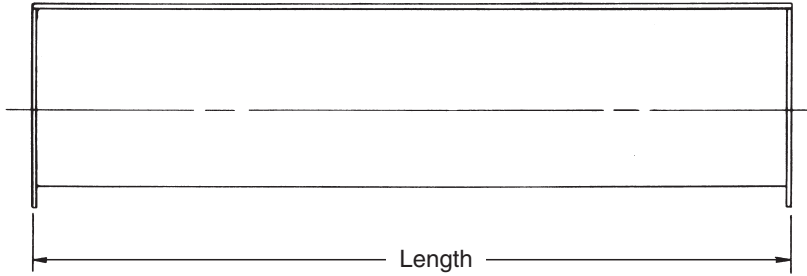

Conveyor Diameter	Trough Thickness	Part Number	Weight Per Foot	A	B	C	D	Standard Length Foot																																																																																																																																																															
6	★ 14 GA.	6FCT14	9	14	16 ⁵ / ₁₆	7	3 ¹ / ₂	10																																																																																																																																																															
6	12	6FCT12	12		16 ¹ / ₁₆				9	★ 14 GA.	9FCT14	13	18	21 ³ / ₁₆	9	5	10	9	12	9FCT12	14	21 ¹ / ₁₆	9	10	9FCT10	19	21 ¹ / ₁₆	9	³ / ₁₆	9FCT7	22	21 ¹ / ₁₆	9	¹ / ₄	9FCT3	25	21 ¹ / ₂	12	★ 12 GA.	12FCT12	20	22	26 ¹ / ₄	10	6 ¹ / ₂	12	12	10	12FCT10	24	26 ¹ / ₄	12	³ / ₁₆	12FCT7	32	26 ³ / ₁₆	12	¹ / ₄	12FCT3	43	26 ¹ / ₂	14	★ 12 GA.	14FCT12	23	24	28 ¹ / ₄	11	7 ¹ / ₂	12	14	10	14FCT10	27	28 ¹ / ₄	14	³ / ₁₆	14FCT7	37	28 ³ / ₁₆	14	¹ / ₄	14FCT3	49	28 ¹ / ₂	16	★ 12 GA.	16FCT12	25	28	32 ¹ / ₄	11 ¹ / ₂	8 ¹ / ₂	12	16	10	16FCT10	31	32 ¹ / ₄	16	³ / ₁₆	16FCT7	39	32 ³ / ₁₆	16	¹ / ₄	16FCT3	52	32 ¹ / ₂	18	★ 12 GA.	18FCT12	27	31	36 ¹ / ₄	12 ¹ / ₂	9 ¹ / ₂	12	18	10	18FCT10	35	36 ¹ / ₄	18	³ / ₁₆	18FCT7	45	36 ³ / ₁₆	18	¹ / ₄	18FCT3	56	36 ¹ / ₂	20	★ 10 GA.	20FCT10	36	34	39 ¹ / ₄	13 ¹ / ₂	10 ¹ / ₂	12	20	³ / ₁₆	20FCT7	48	39 ³ / ₁₆	20	¹ / ₄	20FCT3	60	39 ¹ / ₂	24	★ 10 GA.	24FCT10	41	40	45 ¹ / ₄	16 ¹ / ₂	12 ¹ / ₂	12	24	³ / ₁₆	24FCT7	54	45 ³ / ₁₆	24
9	★ 14 GA.	9FCT14	13	18	21 ³ / ₁₆	9	5	10																																																																																																																																																															
9	12	9FCT12	14		21 ¹ / ₁₆																																																																																																																																																																		
9	10	9FCT10	19		21 ¹ / ₁₆																																																																																																																																																																		
9	³ / ₁₆	9FCT7	22		21 ¹ / ₁₆																																																																																																																																																																		
9	¹ / ₄	9FCT3	25		21 ¹ / ₂																																																																																																																																																																		
12	★ 12 GA.	12FCT12	20	22	26 ¹ / ₄	10	6 ¹ / ₂	12																																																																																																																																																															
12	10	12FCT10	24		26 ¹ / ₄																																																																																																																																																																		
12	³ / ₁₆	12FCT7	32		26 ³ / ₁₆																																																																																																																																																																		
12	¹ / ₄	12FCT3	43		26 ¹ / ₂																																																																																																																																																																		
14	★ 12 GA.	14FCT12	23	24	28 ¹ / ₄	11	7 ¹ / ₂	12																																																																																																																																																															
14	10	14FCT10	27		28 ¹ / ₄																																																																																																																																																																		
14	³ / ₁₆	14FCT7	37		28 ³ / ₁₆																																																																																																																																																																		
14	¹ / ₄	14FCT3	49		28 ¹ / ₂																																																																																																																																																																		
16	★ 12 GA.	16FCT12	25	28	32 ¹ / ₄	11 ¹ / ₂	8 ¹ / ₂	12																																																																																																																																																															
16	10	16FCT10	31		32 ¹ / ₄																																																																																																																																																																		
16	³ / ₁₆	16FCT7	39		32 ³ / ₁₆																																																																																																																																																																		
16	¹ / ₄	16FCT3	52		32 ¹ / ₂																																																																																																																																																																		
18	★ 12 GA.	18FCT12	27	31	36 ¹ / ₄	12 ¹ / ₂	9 ¹ / ₂	12																																																																																																																																																															
18	10	18FCT10	35		36 ¹ / ₄																																																																																																																																																																		
18	³ / ₁₆	18FCT7	45		36 ³ / ₁₆																																																																																																																																																																		
18	¹ / ₄	18FCT3	56		36 ¹ / ₂																																																																																																																																																																		
20	★ 10 GA.	20FCT10	36	34	39 ¹ / ₄	13 ¹ / ₂	10 ¹ / ₂	12																																																																																																																																																															
20	³ / ₁₆	20FCT7	48		39 ³ / ₁₆																																																																																																																																																																		
20	¹ / ₄	20FCT3	60		39 ¹ / ₂																																																																																																																																																																		
24	★ 10 GA.	24FCT10	41	40	45 ¹ / ₄	16 ¹ / ₂	12 ¹ / ₂	12																																																																																																																																																															
24	³ / ₁₆	24FCT7	54		45 ³ / ₁₆																																																																																																																																																																		
24	¹ / ₄	24FCT3	69		45 ¹ / ₂																																																																																																																																																																		

★Standard Gauge

See Page 43 for Bolt Pattern

Saddles — Feet Trough End Flanges

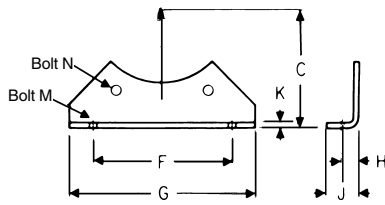

Flange Foot

Trough feet are used to support trough at trough connections.

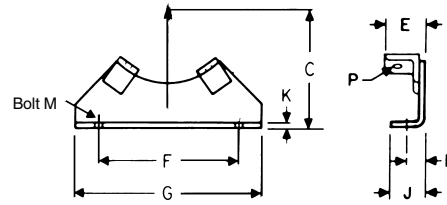

Saddle**

Trough saddles are used to support trough where flange feet cannot be used at connections.

Conveyor Diameter	Part Number					Weight				
	Saddle		Flange Foot			Saddle		Flange Foot		
4	4TS		4TFF			1.5		1.5		
6	6TS		6TFF			2.0		2.0		
9	9TS		9TFF			4.5		4.5		
10	10TS		10TFF			5.0		5.0		
12	12TS		12TFF			6.0		6.0		
14	14TS		14TFF			7.0		7.0		
16	16TS		16TFF			8.0		7.5		
18	18TS		18TFF			10		9.5		
20	20TS		20TFF			13		12.5		
24	24TS		24TFF			15		14.5		

Conveyor Diameter	C	E	F	G	H	J	K	M*	N	P
4	4 $\frac{5}{8}$	1 $\frac{1}{16}$	5 $\frac{3}{4}$	7 $\frac{5}{8}$	$\frac{7}{8}$	1 $\frac{1}{2}$	$\frac{3}{16}$	$\frac{3}{8}$	$\frac{3}{8}$	$\frac{1}{4}$
6	5 $\frac{5}{8}$	1 $\frac{3}{16}$	8 $\frac{1}{8}$	10	$\frac{13}{16}$	1 $\frac{1}{2}$	$\frac{3}{16}$	$\frac{3}{8}$	$\frac{3}{8}$	$\frac{1}{4}$
9	7 $\frac{5}{8}$	1 $\frac{1}{2}$	9 $\frac{5}{8}$	12	1 $\frac{1}{16}$	2 $\frac{1}{2}$	$\frac{3}{16}$	$\frac{1}{2}$	$\frac{3}{8}$	$\frac{3}{8}$
10	8 $\frac{7}{8}$	1 $\frac{1}{2}$	9 $\frac{1}{2}$	12 $\frac{3}{8}$	1 $\frac{1}{16}$	2 $\frac{1}{2}$	$\frac{3}{16}$	$\frac{5}{8}$	$\frac{3}{8}$	$\frac{3}{8}$
12	9 $\frac{5}{8}$	1 $\frac{1}{2}$	12 $\frac{1}{4}$	15	1 $\frac{3}{8}$	2 $\frac{1}{2}$	$\frac{1}{4}$	$\frac{5}{8}$	$\frac{1}{2}$	$\frac{1}{2}$
14	10 $\frac{7}{8}$	1 $\frac{3}{4}$	13 $\frac{1}{2}$	16 $\frac{1}{2}$	1 $\frac{3}{8}$	2 $\frac{1}{2}$	$\frac{1}{4}$	$\frac{5}{8}$	$\frac{1}{2}$	$\frac{1}{2}$
16	12	1 $\frac{3}{4}$	14 $\frac{3}{4}$	18	1 $\frac{3}{4}$	3	$\frac{1}{4}$	$\frac{5}{8}$	$\frac{5}{8}$	$\frac{1}{2}$
18	13 $\frac{3}{8}$	1 $\frac{3}{4}$	16	19 $\frac{1}{4}$	1 $\frac{3}{4}$	3	$\frac{1}{4}$	$\frac{5}{8}$	$\frac{5}{8}$	$\frac{1}{2}$
20	15	2 $\frac{1}{4}$	19 $\frac{1}{4}$	22 $\frac{3}{4}$	2	3 $\frac{1}{2}$	$\frac{1}{4}$	$\frac{3}{4}$	$\frac{5}{8}$	$\frac{5}{8}$
24	18 $\frac{1}{8}$	2 $\frac{1}{4}$	20	24	2 $\frac{1}{4}$	4	$\frac{1}{4}$	$\frac{3}{4}$	$\frac{5}{8}$	$\frac{5}{8}$

*Holes for Bolt M Slotted

** Alternate saddle type available. Contact TCC for more information.

Trough End Flanges

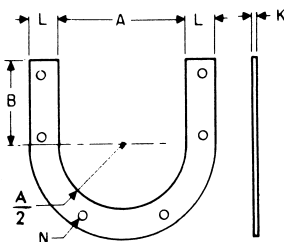

Size	Part No.	A		B	K	L	N	Weight	Black Neoprene Gasket**
		Trough Thickness							
		Thru 10 Ga.	$\frac{3}{16}$ & $\frac{1}{4}$						
4	4TF*	5 $\frac{1}{4}$	5 $\frac{5}{8}$	3 $\frac{5}{8}$	$\frac{3}{16}$	1 $\frac{1}{4}$	$\frac{3}{8}$	0.9	4TFG-B
6	6TF*	7 $\frac{1}{4}$	7 $\frac{3}{8}$	4 $\frac{1}{2}$	$\frac{3}{16}$	1 $\frac{1}{2}$	$\frac{3}{8}$	1.5	6TFG-B
9	9TF*	10 $\frac{1}{4}$	10 $\frac{1}{2}$	6 $\frac{1}{2}$	$\frac{3}{16}$	1 $\frac{3}{4}$	$\frac{3}{8}$	2.4	9TFG-B
10	10TF*	11 $\frac{1}{4}$	11 $\frac{1}{2}$	6 $\frac{3}{8}$	$\frac{3}{16}$	1 $\frac{3}{4}$	$\frac{3}{8}$	2.6	10TFG-B
12	12TF*	13 $\frac{1}{4}$	13 $\frac{1}{2}$	7 $\frac{3}{4}$	$\frac{1}{4}$	2	$\frac{1}{2}$	5.6	12TFG-B
14	14TF*	15 $\frac{1}{4}$	15 $\frac{1}{2}$	9 $\frac{1}{4}$	$\frac{1}{4}$	2	$\frac{1}{2}$	6.5	14TFG-B
16	16TF*	17 $\frac{1}{4}$	17 $\frac{1}{2}$	10 $\frac{5}{8}$	$\frac{1}{4}$	2	$\frac{5}{8}$	7.4	16TFG-B
18	18TF*	19 $\frac{1}{4}$	19 $\frac{1}{2}$	12 $\frac{1}{2}$	$\frac{1}{4}$	2 $\frac{1}{2}$	$\frac{5}{8}$	10.2	18TFG-B
20	20TF*	21 $\frac{1}{4}$	21 $\frac{1}{2}$	13 $\frac{1}{2}$	$\frac{1}{4}$	2 $\frac{1}{2}$	$\frac{5}{8}$	11.3	20TFG-B
24	24TF*	25 $\frac{1}{4}$	25 $\frac{1}{2}$	16 $\frac{1}{2}$	$\frac{1}{4}$	2 $\frac{1}{2}$	$\frac{5}{8}$	15.5	24TFG-B

*-10 used for troughs through 10 ga., -3 used for troughs $\frac{3}{16}$ " and $\frac{1}{4}$ " thick.

**Also available in White Nitrile, High Temp, and other gasket material.

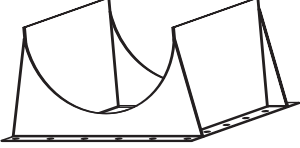
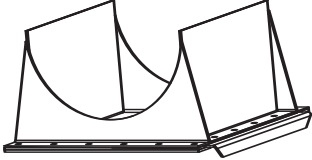
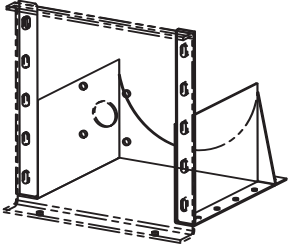
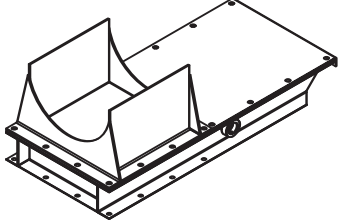
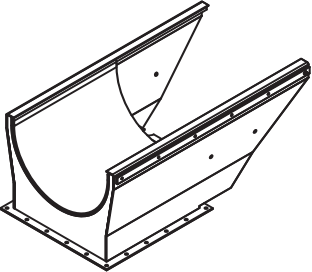
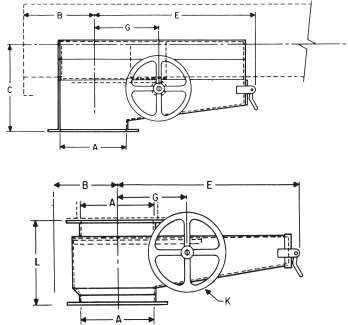
Discharge Spout Index		14	TSD	12
Conveyor Diameter	Types			Spout Thickness
	TSD - Plain, Fixed Spout TSDS - Plain Fixed Spout W/Slide TSDF - Flush End Spout RPF - Rack & Pinion/Flat Side			14 - 14 Gauge 12 - 12 Gauge 10 - 10 Gauge 7 - 3/16
STANDARD DISCHARGE SPOUT		Most commonly used. Flanged hole drilling is per CEMA Standards. Select spout thickness according to trough thickness.		
STANDARD DISCHARGE SPOUT WITH HAND SLIDE		Standard spout shown above with the addition of the slide and side guides. Select spout thickness according to trough thickness.		
FLUSH END DISCHARGE SPOUT		Reduces distance from centerline of discharge to end of the conveyor which eliminates ledge at end of trough and product build-up. Special flush-end trough ends required when this style of discharge is used.		
FLAT SLIDE GATE		Rack & pinion type available with hand wheel, rope wheel, pocket wheel and chain. Discharge spout is included when fitted. Flat slide (less rack & pinion) can be furnished with pneumatic, hydraulic, or electric actuators. (Not dust-tight).		
CURVED SLIDE GATE		Contoured shape of slide eliminates pocket found in flat slide type. Rack & pinion type available with handwheel, or rope wheel, or pocket wheel with chain. Curved slide (less rack & pinion) can be furnished with pneumatic, hydraulic, or electric actuators. (Standard curved slide gate is not dust-tight.) All curved slide gates should be installed at factory .		
DUST TIGHT RACK AND PINION FLAT SLIDE		Dust tight rack and pinions are totally enclosed and can be furnished with either flat or curved slide. Handwheel is normally furnished but is also available with chain or rope wheel.		

Discharge Spouts



Plain Opening

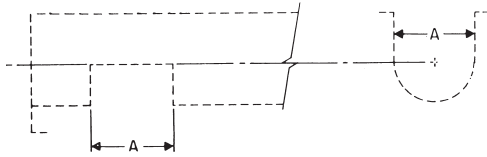

Plain spout openings are cut in the trough permitting free material discharge.

Fixed Spout with Slide Gate

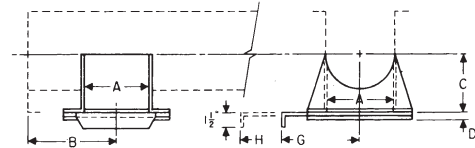

Fixed spouts with slide gates are used where distribution of material is to be controlled. Bolted flange permits slide to be operated from any side.

Fixed Spout

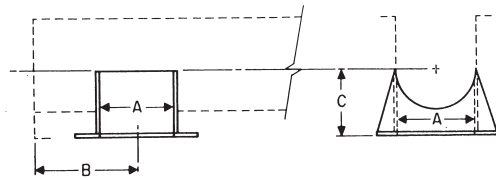

Fixed spouts are fabricated in proportion to size and thickness of trough. Can be furnished loose or welded to trough.

Flush End Spout

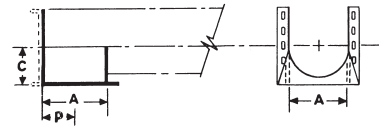

Flush end discharge spouts are designed for use at the final discharge point. The end of the spout is comprised of a housing end with bottom flange drilled with standard discharge flange bolt pattern. Because it is located at the extreme end of the conveyor, there is no carryover of material past the final discharge point. The flush end arrangement eliminates the unnecessary extension of trough and interior components beyond the actual discharge point.

Screw Diameter	A	B	C	D	G	H	F
4	5	4½	3¼	5/16	5%	11	2½
6	7	6	5	5/16	6%	14	3½
9	10	8	7%	5/16	8	19	5
10	11	9	7%	5/16	8%	20	5½
12	13	10½	8%	5/16	10%	24	6½
14	15	11½	10%	5/16	11¼	27	7½
16	17	13½	11%	5/16	12%	30	8½
18	19	14½	12%	5/16	13%	33	9½
20	21	15½	13%	3/8	14%	36	10½
24	25	17½	15%	3/8	16%	42	12½

Screw Diameter	Trough Thickness Gauge	Spout and Gate Thickness Gauge	Part Number			Weight		
			Fixed Spout		Flush End Spout	Fixed Spout		Flush End Spout
			Plain	With Slide		Plain	Slide	
4	14	★ 14	4TSD14	4TSDS14	4TSDF14	2	6	1.6
4	12	12	4TSD12	4TSDS12	4TSDF12	3	7	2.25
6	14-12	★ 14	6TSD14	6TSDS14	6TSDF14	4	11	3.0
6	5/16-1/4	12	6TSD12	6TSDS12	6TSDF12	6	13	4.50
9	14-12-10	★ 14	9TSD14	9TSDS14	9TSDF14	8	18	6.0
9	5/16-1/4	10	9TSD10	9TSDS10	9TSDF10	13	22	9.75
10	14-12-10	★ 14	10TSD14	10TSDS14	10TSDF14	10	21	7.5
10	5/16-1/4	10	10TSD10	10TSDS10	10TSDF10	16	27	12.0
12	12-10	★ 12	12TSD12	12TSDS12	12TSDF12	17	36	12.75
12	5/16-1/4	5/16	12TSD7	12TSDS7	12TSDF7	29	48	21.75
14	12-10	★ 12	14TSD12	14TSDS12	14TSDF12	22	46	16.50
14	5/16-1/4	3/16	14TSD7	14TSDS7	14TSDF7	38	62	28.50
16	12-10	★ 12	16TSD12	16TSDS12	16TSDF12	21	49	15.75
16	5/16-1/4	3/16	16TSD7	16TSDS7	16TSDF7	40	68	30.0
18	12-10	★ 12	18TSD12	18TSDS12	18TSDF12	32	69	24.0
18	5/16-1/4	5/16	18TSD7	18TSDS7	18TSDF7	60	97	45.0
20	10	★ 12	20TSD12	20TSDS12	20TSDF12	40	91	30.0
20	5/16-1/4	5/16	20TSD7	20TSDS7	20TSDF7	67	118	50.25
24	10	★ 12	24TSD12	24TSDS12	24TSDF12	52	116	39.0
24	5/16-1/4	5/16	24TSD7	24TSDS7	24TSDF7	87	151	65.25

★ Standard Gauge
For Bolt Patterns See Page 44

Flat rack and pinion slide gates can be bolted to standard discharge spouts at any of the four positions desired. Hand wheel is normally furnished but is also available with chain or rope wheel.

Rack and Pinion Flat Slide

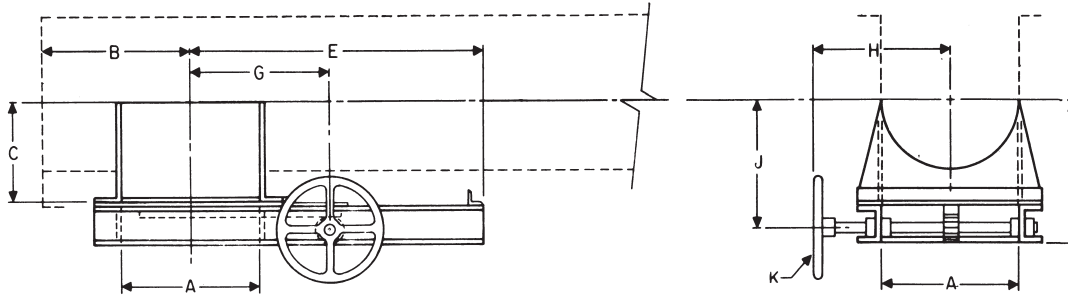

Screw Diameter	A	B	C	D	E	G	H	J	K Diameter
4	5	4½	3¾	7	13½	6½	5	5½	12
6	7	6	5	8¾	16	7½	6	6¾	12
9	10	8	7½	10%	20¼	9	9½	8%	12
10	11	9	7½	11½	23½	10½	10	9%	12
12	13	10½	8%	12½	25½	11	12¼	10%	12
14	15	11½	10%	13%	31¼	12½	13¼	12	12
16	17	13½	11½	14%	33%	13½	14¼	13	12
18	19	14½	12%	15%	37%	14½	15%	14½	12
20	21	15½	13%	16¼	40%	15½	16%	15%	12
24	25	17½	15%	18¼	46½	17½	18%	17%	12

Screw Diameter	Trough Thickness Gauge	Spout and Gate Thickness Gauge	Part Number Rack and Pinion * †	Weight Rack and Pinion
4	14	★ 14	4RPF14	18
4	12	12	4RPF12	21
6	14-12	★ 14	6RPF14	28
6	⅜	12	6RPF12	31
9	14-12-10	★ 14	9RPF14	49
9	⅜-¼	10	9RPF10	54
10	14-12-10	★ 14	10RPF14	56
10	⅜-¼	10	10RPF10	62
12	12-10	★ 12	12RPF12	94
12	⅜-¼	⅜	12RPF7	106
14	12-10	★ 12	14RPF12	107
14	⅜-¼	⅜	14RPF7	123
16	12-10	★ 12	16RPF12	112
16	⅜-¼	⅜	16RPF7	131
18	12-10	★ 12	18RPF12	157
18	⅜-¼	⅜	18RPF7	185
20	10	★ 12	20RPF12	185
20	⅜-¼	⅜	20RPF7	212
24	10	★ 12	24RPF12	233
24	⅜-¼	⅜	24RPF7	268

* Handwheel supplied as Standard Assembly
 — C Chain Wheel
 — R Rope Wheel

★ Standard Gauge
 For Bolt Patterns See Page 44
 † All Rack & Pinion Gates 18" and Larger Have Double Rack & Pinion.

Discharge Gates



Rack and Pinion Curved Slide

Curved rack and pinion slide gates are contoured to the shape of the trough thus eliminating pocket caused by flat slide. Slide operates parallel to the trough only. Hand wheel is normally furnished but is also available with chain or rope wheel.

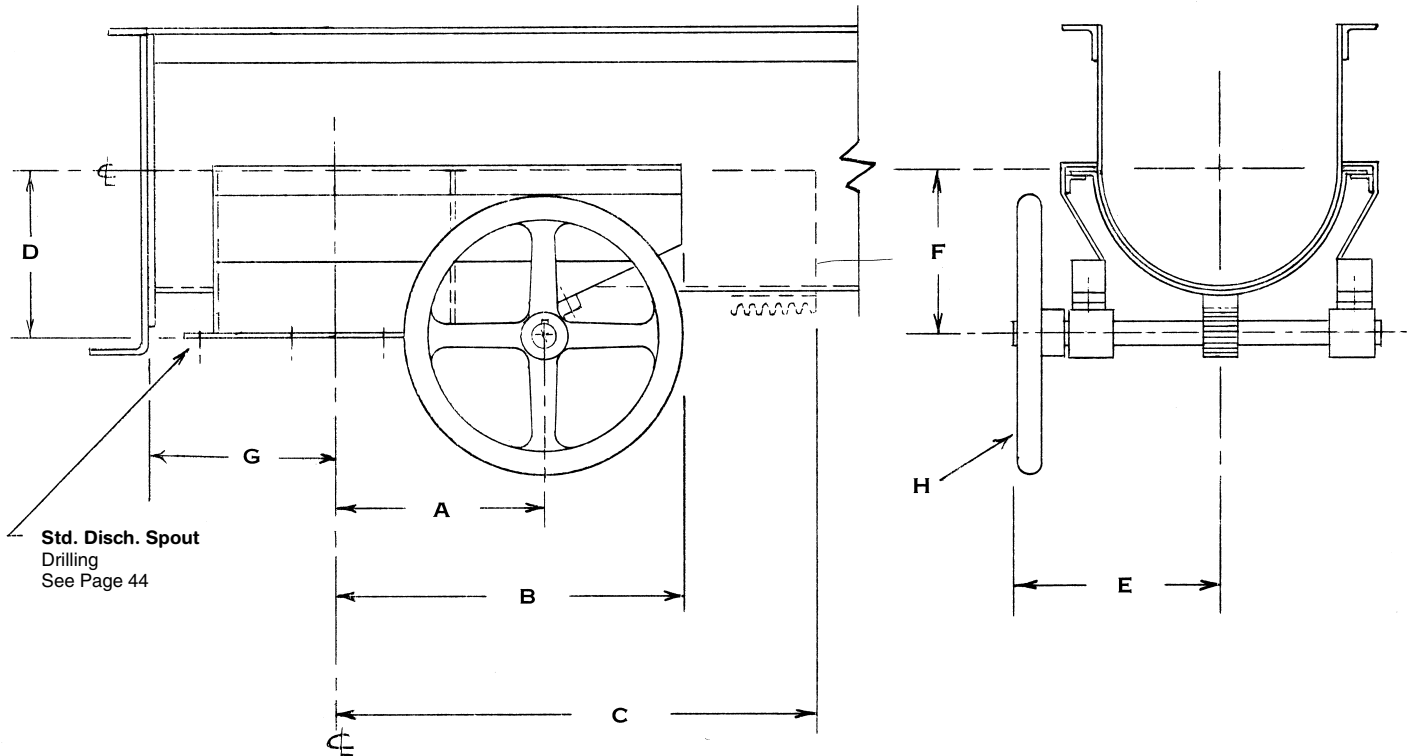

Std. Disch. Spout
Drilling
See Page 44

Conveyor Diameter	Trough Thickness Gauge	Spout Thickness Gauge	Part Number ^①	Weight Pounds	A	B	C	D	E	F	G	H Diameter
4	14	★ 14	4RPC14	20	6¼	8¼	12	3¼	6	4½	4½	12
4	12	12	4RPC12	22	6¼	8¼	12	3¼	6	4⅝		
6	16-14-12	★ 14	6RPC14	25	7½	10½	15	5	8	5½	6	12
6	¾	12	6RPC12	28	7½	10½	15	5	8	5⅝		
9	14-12-10	★ 14	9RPC14	46	9	15	20½	7⅞	8¼	7	8	12
9	⅝-¼	10	9RPC10	54	9	15	20½	7⅞	8¼	7⅞		
10	14-12-10	★ 14	10RPC14	53	9½	14½	21	7⅞	9⅞	7½	9	12
10	⅝-¼	10	10RPC10	62	9½	14½	21	7⅞	9⅞	7⅞		
12	12-10	★ 12	12RPC12	81	11⅞	17½	25¼	8⅞	11	8½	10½	12
12	⅝-¼	¾	12RPC7	97	11⅞	17½	25¼	8⅞	11	8⅞		
14	10-12	★ 12	14RPC12	95	12⅞	20½	30¼	10⅞	12	9½	11½	12
14	⅝-¼	¾	14RPC7	114	12⅞	20½	30¼	10⅞	12	9⅞		
16	10-12	★ 12	16RPC12	103	14⅞	23½	36	11⅞	13	10½	13½	12
16	⅝-¼	¾	16RPC7	116	14⅞	23½	36	11⅞	13	10⅞		
18	10-12	★ 12	18RPC12	157	15⅞	25½	37¼	12⅞	15⅞	11½	14½	12
18	⅝-¼	¾	18RPC7	187	15⅞	25½	37¼	12⅞	15⅞	11⅞		
20	12	★ 12	20RPC12	175	17⅞	28½	39	13⅞	16⅞	12½	15½	12
20	⅝-¼	¾	20RPC7	208	17⅞	28½	39	13⅞	16⅞	12⅞		
24	10	★ 12	24RPC12	220	19⅞	35½	47	15⅞	18⅞	14½	17½	12
24	⅝-¼	¾	24RPC7	265	19⅞	35½	47	15⅞	18⅞	14⅞		

* Hand wheel supplied as Standard Assembly
— C Chain Wheel
— R Rope Wheel

★ Standard Gauge

① All curved slide gates should be installed at factory.

Dust Tight Rack and Pinion Flat Slide

Dust tight rack and pinions are totally enclosed and can be furnished with either flat or curved slide. Handwheel is normally furnished but is also available with chain or rope wheel.

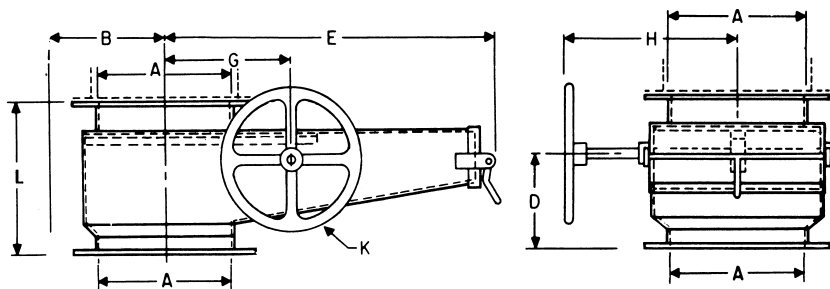

Dust Tight Rack and Pinion Curved Slide

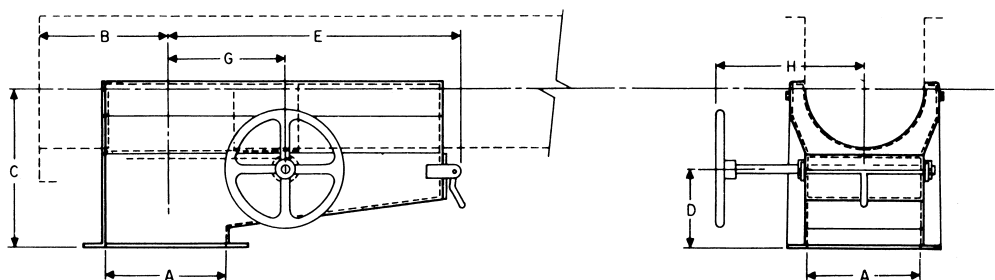

Screw Diameter	A	B	C	D	E	G	H	K Diameter	L
4	5	4½	7½	2½	12	6	7	12	7½
6	7	6	10	4	18½	7½	8	12	9
9	10	8	12½	5	23	9	11	12	10
10	11	9	13	5	25	10	11½	12	10½
12	13	10½	15	5	28	11½	13	12	10½
14	15	11½	15½	5½	31	12½	14	12	10½
16	17	13½	16½	5½	34	13½	15	12	10½
18	19	14½	18½	6½	38½	15	16½	12	11½
20	21	15½	20	7	40½	16	17½	12	12
24	25	17½	23	8	47½	18	19½	12	13

Screw Diameter	Trough Thickness Gauge	Spout and Slide Thickness Gauge	Part Number			
			Flat Slide *	Weight	Curved Slide * ①	Weight
4	14	14	4RPF14	27	4RPCD14	30
4	12	12	4RPF12	32	4RPCD12	35
6	14-12	14	6RPF14	42	6RPCD14	46
6	¾	12	6RPF12	47	6RPCD12	52
9	14-12-10	12	9RPF12	74	9RPCD12	81
9	¾-¼	10	9RPF10	81	9RPCD10	89
10	14-12-10	14	10RPF14	84	10RPCD14	92
10	¾-¼	10	10RPF10	93	10APCD10	102
12	12-10	12	12RPF12	141	12RPCD12	155
12	¾-¼	¾	12RPF7	158	12RPCD7	174
14	12-10	12	14RPF12	160	14RPCD12	176
14	¾-¼	¾	14RPF7	185	14RPCD7	204
16	12-10	12	16RPF12	168	16RPCD12	185
16	¾-¼	¾	16RPF7	197	16RPCD7	217
18	12-10	12	18RPF12	240	18RPCD12	264
18	¾-¼	¾	18RPF7	277	18RPCD7	305
20	10	12	20RPF12	278	20RPCD12	306
20	¾-¼	¾	20RPF7	318	20RPCD7	350
24	10	12	24RPF12	350	24RPCD12	385
24	¾-¼	¾	24RPF7	402	24RPCD7	442

* Handwheel supplied as standard assembly
 — C Chain Wheel
 — R Rope Wheel

Flange drilling is standard. See page 44.
 ① All curved slide gates should be installed at factory.

Discharge Gate Accessories

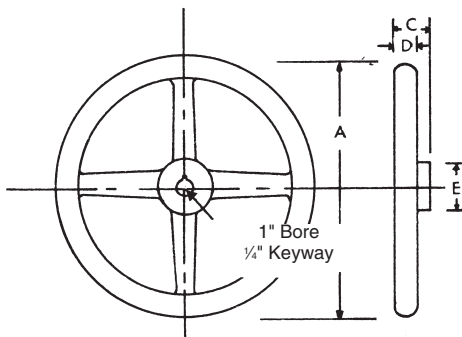

Hand Wheel

Dimensions in Inches and Weight in Pounds

Wheel Diameter	Part No.	Weight	C	D	E
12	12HW1	11	2	1 1/2	1 1/2

The hand wheel is regularly furnished to rotate the pinion shaft when the slide gate is readily accessible.

NOTE: Zinc or nickel plated hand wheels available on request.

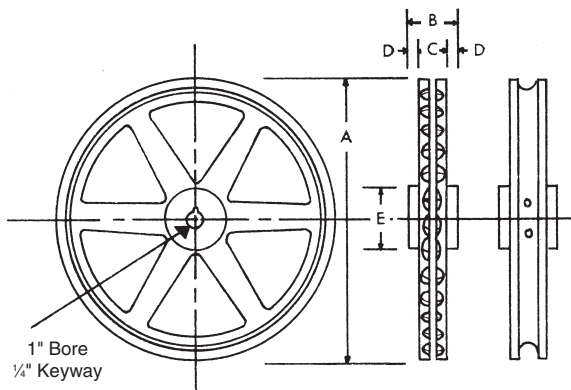

Pocket Wheel & Rope Wheel

Dimensions in Inches and Average Weights in Pounds

Wheel Diameter	Part No.	Weight	A	B	C	D	E
Chain Wheel	20PW1	11	12 3/4	2	1 1/2	3/16	2
Rope Wheel	12RW1	13	12 1/2	2 1/4	1 1/2	1 1/4	1 1/2

Pocket chain and rope wheels are used to rotate pinion shaft where remote operation is desired. It is designed to be used with number 3/16 pocket chain.

NOTE: Zinc or nickel plated hand wheels available on request.

Hanger Pockets

Hanger pockets are used with tubular trough and are mounted on the trough at bearing connections. The hanger pocket forms a "U" shaped section for a short distance, allowing the use of standard hangers and providing easy access to them.

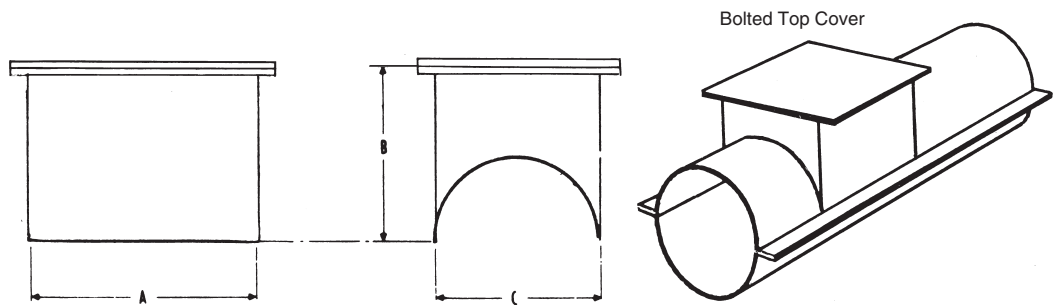

Conveyor Diameter	Part Number	A	B	C	Weight Each
4	4CPH14	8	3 3/4	5	2
6	6CPH14	12	4 3/4	7	3
9	9CPH14	12	6 3/8	10	4
10	10CPH14	12	6 1/2	11	9
12	12CPH12	18	8	13	18
14	14CPH12	18	9 1/2	15	24
16	16CPH12	17	11 1/2	17	26
18	18CPH12	19	12 3/4	19	55
20	20CPH10	21	13 3/4	21	70
24	24CPH10	25	15 3/4	25	85

Trough Cover	14	TCP	14
Conveyor Diameter		Type	Cover Thickness
		TCP – Plain	14 – 14 GA.
		TCS – Semi Flanged	12 – 12 GA.
		TCF – Flanged	10 – 10 GA.
		TCH – Hip Roof	7 – 3/16"
		TSC – Shroud	

It is the responsibility of the contractor, installer, owner and user to install, maintain and operate the conveyor components and conveyor assemblies manufactured and supplied by TCC in such a manner as to comply with the Williams-Steiger Occupational Safety and Health Act and with all state and local laws and ordinances and the American National Standard Institute Safety Code.

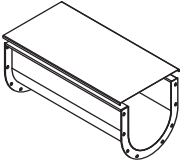
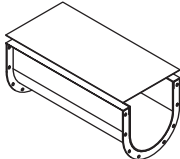
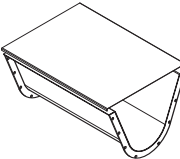
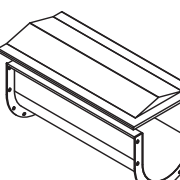
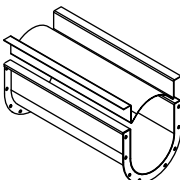
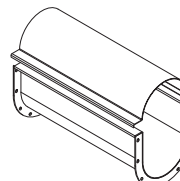
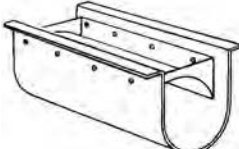
Flanged Covers		Most commonly used. Can be supplied with gaskets and butt straps for dust tight applications. Semi-flanged must be furnished if spring clamps are used.
Flat Covers		Usually used only to cover conveyor for safety.
Flared Trough Covers		Usually flanged type and heavier gauges because of span.
Hip Roof Covers		Hip roof covers are similar to conventional flanged covers except they are peaked slightly to form a ridge along the center of the cover. A welded end plate closes the peaked section at each end of the trough while intermediate joints are usually buttstrap connected. Hip roof covers are usually recommended for outdoor installations to prevent accumulation of moisture. They are also often used in applications where a more rigid cover is required.
Shroud Covers		Used to approximate tubular cross section for inclined or feeder applications.
Domed Covers		Domed covers are half circle domes rolled to the same inside diameter as the trough bottom and are flanged for bolting to the trough top rails. They are used where venting of fumes or heat from the material being conveyed is required. End sections have a welded end plate and intermediate joints are buttstrap connected. Vent pipes or suction lines can be attached to the cover.
Feeder Shrouds		Shrouds are used in trough sections of screw feeders to decrease the clearance between the cover and feeder screw to obtain proper feed regulation. Lengths are sufficient to prevent flushing of the majority of materials being handled and gauges are proportioned to trough size and gauge.

Trough Covers

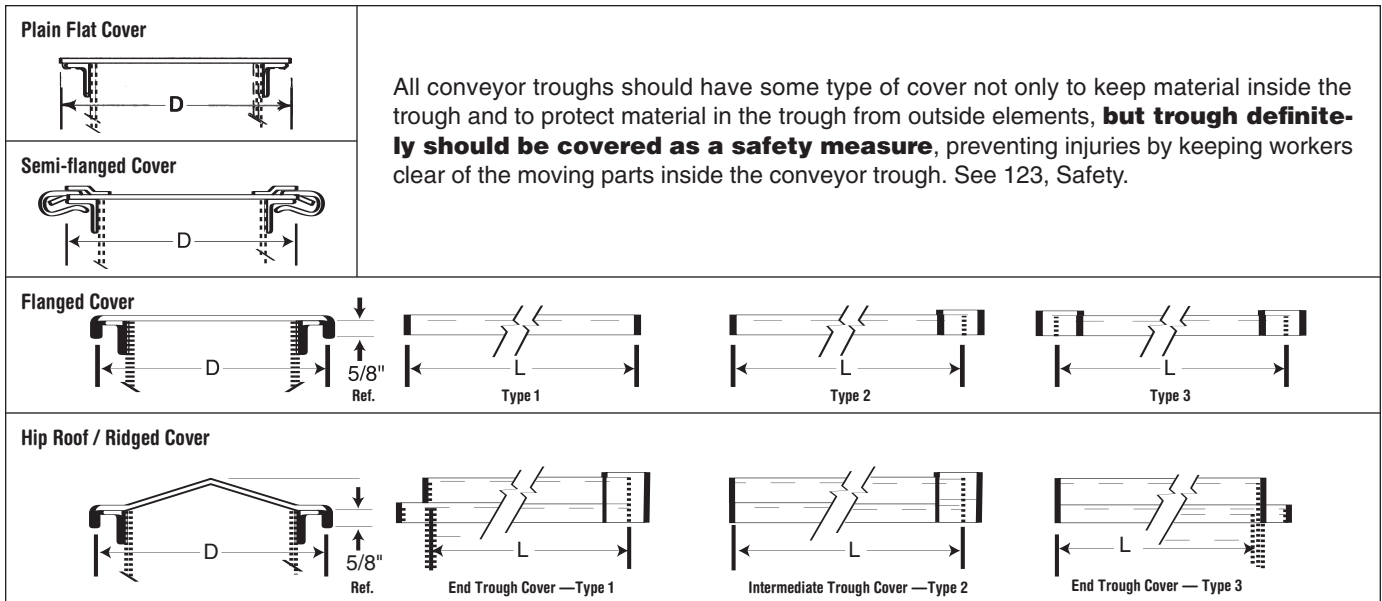

Conveyor Diameter	Plain Flat Cover				Plain Semi-Flanged Cover				Flanged Cover				Hip Roof / Ridged Cover			
	Part Number	Thick-ness Ga.	Wt. Per Fl.	D	Part Number	Thick-ness Ga.	Wt. Per Fl.	D	Part Number	Thick-ness Ga.	Wt. Per Fl.	D	Part Number	Thick-ness Ga.	Wt. Per Fl.	D
4 *	4TCP14	14	2.0	7%	4TCS14 4TCS12	★ 14 12	2.6 3.2	7%	4TCF14 4TCF12	★ 14 12	2.4 3.1	7%	4TCH14 4TCH12	★ 14 12	2.5 3.3	7%
6 *	6TCP14	14	2.5	9%	6TCS14 6TCS12	★ 14 12	3.8 4.4	9%	6TCF14 6TCF12	★ 14 12	2.6 3.4	10%	6TCH14 6TCH12	★ 14 12	2.8 3.7	10%
9 *	9TCP14	14	3.5	13%	9TCS14 9TCS12 9TCS10	★ 14 12 10	4.1 5.7 7.3	13%	9TCF14 9TCF12 9TCF10	★ 14 12 10	3.9 5.5 7.1	13%	9TCH14 9TCH12	★ 14 12	4.1 5.4	13%
10 *	10TCP14	14	3.8	14%	10TCS14 10TCS12 10TCS10	★ 14 12 10	4.4 6.1 7.8	14%	10TCF14 10TCF12 10TCF10	★ 14 12 10	4.2 5.9 7.6	14%	10TCH14 10TCH12	★ 14 12	4.3 5.6	14%
12 **	12TCP14	14	4.6	17½%	12TCS14 12TCS12 12TCS10	★ 14 12 10	5.1 7.1 9.0	17½%	12TCF14 12TCF12 12TCF10	★ 14 12 10	4.9 6.9 8.8	17½%	12TCH14 12TCH12	★ 14 12	5.0 7.1	17½%
14 **	14TCP14	14	5.1	19½%	14TCS14 14TCS12 14TCS10	★ 14 12 10	5.6 7.8 9.9	19½%	14TCF14 14TCF12 14TCF10	★ 14 12 10	5.4 7.6 9.7	19½%	14TCH14 14TCH12	★ 14 12	5.5 7.7	19½%
16 **	16TCP14	14	5.6	21½%	16TCS14 16TCS12 16TCS10	★ 14 12 10	6.1 8.5 10.8	21½%	16TCF14 16TCF12 16TCF10	★ 14 12 10	5.9 8.3 10.6	21½%	16TCH14 16TCH12	★ 14 12	6.1 8.5	21½%
18 **	18TCP12	12	8.9	24%	18TCS12 18TCS10	★ 12 10	9.6 12.3	24%	18TCF12 18TCF10	★ 12 10	9.4 12.1	24%	18TCH12 18TCH10	★ 12 10	9.5 12.4	24%
20 **	20TCP12	12	9.7	26%	20TCS12 20TCS10	★ 12 10	10.3 13.3	26%	20TCF12 20TCF10	★ 12 10	10.1 13.1	26%	20TCH12 20TCH10	★ 12 10	10.4 13.5	26%
24 **	24TCP12	12	11.1	30%	24TCS12 24TCS10	★ 12 10	11.8 15.1	30%	24TCF12 24TCF10	★ 12 10	11.6 14.9	30%	24TCH12 24TCH10	★ 12 10	11.8 12.3	30%

For average applications where dust confinement is not a problem, 2'-0" centers or 10 fasteners per 10'-0" section are generally satisfactory. For commercially dust tight 1'-0" centers or 20 fasteners per 10'-0" section are suggested.

*L — Standard length is 10'-0"

**L — Standard length is 12'-0"

★ — Standard gauge

Flanged Conveyor Inlets

The two styles of flanged conveyor inlets are designed for either bolting or welding to flat or flanged conveyor trough cover. The inlet inside dimensions and bolt arrangement are the same as the standard conveyor discharge spout.

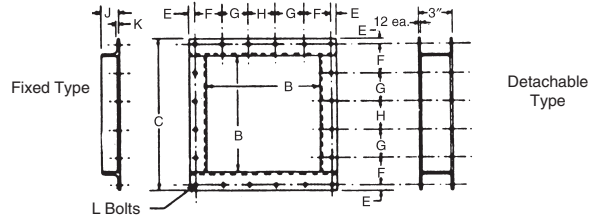

Conveyor Diameter	Part Number		Weight	B	C		E		F	G	H	J	K	L
	Fixed Inlet	Detachable Inlet			Fixed Inlet	Detachable Inlet	Fixed Inlet	Detachable Inlet						
4	4CIF	4CID	1.8	5	7½	7½	¾	¾	2¼	—	2¼	1¼	⅛	¼
6	6CIF	6CID	5.0	7	10	10	1⅞	1⅞	2⅞	—	3	1½	⅜	⅜
9	9CIF	9CID	6.8	10	13	13	½	½	4	—	4	1½	⅜	⅜
10	10CIF	10CID	7.4	11	14	14¼	½	½	4⅞	—	4⅞	1½	⅜	⅜
12	12CIF	12CID	12.1	13	17	17¼	¾	¾	5½	—	5¼	2	⅜	⅜
14	14CIF	14CID	13.7	15	19	19¼	¾	¾	3½	3½	3½	2	⅜	⅜
16	16CIF	16CID	15.8	17	21	21¼	¾	¾	3¾	4	4	2	¼	⅜
18	18CIF	18CID	29.0	19	24	24¼	1	1½	4⅞	4¾	4¾	2½	¼	½
20	20CIF	20CID	31.8	21	26	26¼	1	1½	4⅞	4¾	4¾	2½	¼	½
24	24CIF	24CID	37.2	25	30	30¼	1	1½	5	5	5½	2½	¼	½

Spring Clamps

Spring Clamps are used to attach plain and semi-flanged covers to trough. These clamps are normally riveted to the trough flange and will pivot to allow removal of cover.

Spring Clamp

Clamp No.	A	B	C	D	E	F	G	H	J	Wt.
SPC—1	⅝	⅜	¼	1¼	1⅜	1½	3	1	⅝	.38

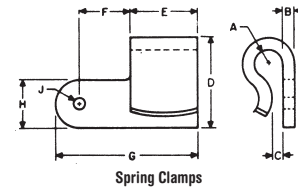

Spring Clamps with Cover Bracket

Spring Clamps with cover brackets are designed to attach to the top side of semi-flanged and plain covers.

Spring Clamp with Cover Bracket

Clamp No.	A	B	C	D	E	F	G	H	J	Wt.
SPCA—1	1⅞	¾	⅜	1¼	1⅞	¾	¾	¾	1¼	.50

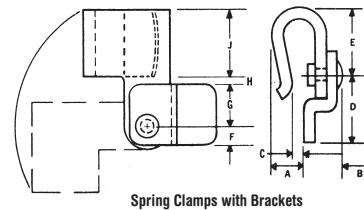

Screw Clamps

Screw Clamps are a simple and effective means of attaching flanged or flat covers to trough.

Screw Clamp

Clamp No.	A	B	C	D	E	F	G	Wt.
CSC—2	2¼	1	1⅞	1¼	⅝	¾	¾	.42

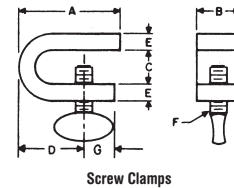

Toggle Clamps

Quick acting toggle clamps are used to attach covers for quick accessibility. Normally this type clamp is attached by welding the front or top of clamp to the trough and can be adjusted to fit all sizes of trough, while allowing 90° to clear working area.

Conveyor	Part Number	No. Required per 10' Section	A	B	C	D	E	F	G
4—24	QTC	6 to 8	7⅞	2⅞	1⅞	2	1¼	⅝	⅝

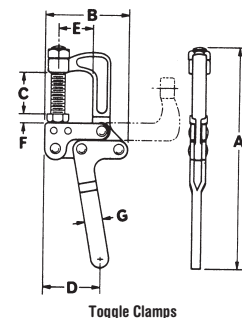

Feeder Shrouds

Shrouds are used in trough sections of screw feeders to decrease the clearance between the cover and feeder screw to obtain proper feed regulation. Lengths are sufficient to prevent flushing of the majority of materials being handled and gauges are proportioned to trough size and gauge.

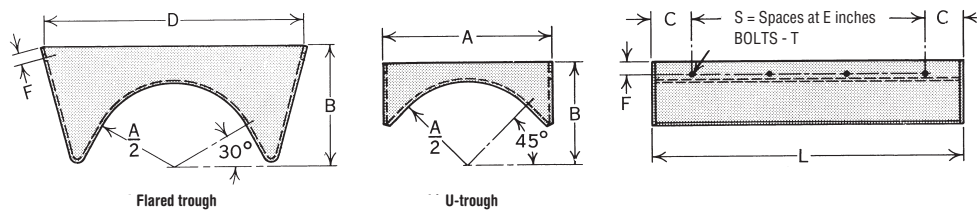

Screw Diameter Inches	Part No.		Shroud Thickness	A	B		C	D	E	F		L	T	S
	U	Flared			U	Flared				U	Flared			
4	4TFS14	4FFS14	14 Ga.	5	3%	—	2	—	4	5/8	—	8	1/4	1
6	6TFS14	6FFS14	14 Ga.	7	4 1/2	7	3	14	6	3/4	3/4	12	5/16	1
	6TFS12	6FFS12	12 Ga.	7	4 1/2	7	3	14	6	3/4	3/4	12	5/16	1
9	9TFS14	9FFS14	14 Ga.	10	6%	9	3	18	6	7/8	3/4	18	3/8	2
	9TFS7	9FFS7	3/16"	10	6%	9	3	18	6	7/8	3/4	18	3/8	2
10	10TFS14	10FFS14	14 Ga.	11	6%	—	2 1/2	—	5	7/8	—	20	3/8	3
	10TFS7	10FFS7	3/16"	11	6%	—	2 1/2	—	5	7/8	—	20	3/8	3
12	12TFS12	12FFS12	12 Ga.	13	7%	10	3	22	6	1 1/8	1	24	3/8	3
	12TFS7	12FFS7	3/16"	13	7%	10	3	22	6	1 1/8	1	24	3/8	3
14	14TFS12	14FFS12	12 Ga.	15	9%	11	3 1/2	24	7	1 1/8	1	28	3/8	3
	14TFS7	14FFS7	3/16"	15	9%	11	3 1/2	24	7	1 1/8	1	28	3/8	3
16	16TFS12	16FFS12	12 Ga.	17	10%	11 1/2	4	28	8	1 1/8	1	32	3/8	3
	16TFS7	16FFS7	3/16"	17	10%	11 1/2	4	28	8	1 1/8	1	32	3/8	3
18	18TFS12	18FFS12	12 Ga.	19	12%	12%	4 1/2	31	9	1 1/8	1 1/8	36	3/8	3
	18TFS7	18FFS7	3/16"	19	12%	12%	4 1/2	31	9	1 1/8	1 1/8	36	3/8	3
20	20TFS10	20FFS10	10 Ga.	21	13 1/2	13 1/2	4	34	8	1 1/8	1 1/8	40	3/8	4
	20TFS7	20FFS7	3/16"	21	13 1/2	13 1/2	4	34	8	1 1/8	1 1/8	40	3/8	4
24	24TFS10	24FFS10	10 Ga.	25	16 1/2	16 1/2	4	40	8	1 1/8	1 1/8	48	3/8	5
	24TFS7	24FFS7	3/16"	25	16 1/2	16 1/2	4	40	8	1 1/8	1 1/8	48	3/8	5

Conveyor Shrouds

Conveyor shroud covers are used to form a tubular cross section within the conveyor trough. This arrangement gives the features of a tubular housing while allowing removal of the shroud for easy access and cleaning. Flat or flanged covers can be used over the shroud cover when it is objectionable for the recess in the shroud to be exposed to dust or weather. Various types of shrouds are furnished to fit various applications. These types are described below.

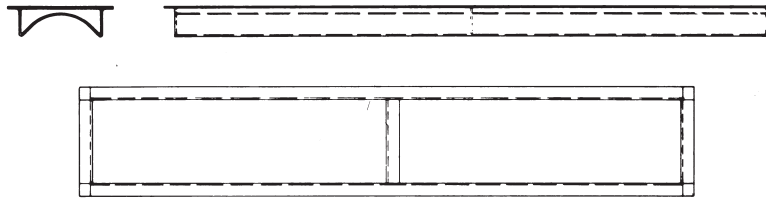

Type 1

Type 1 Shroud cover has flanged sides over top rail and flanged ends at both ends. This type is used when shroud is full length of trough or between hangers.

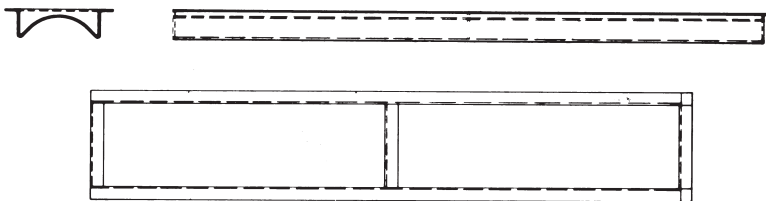

Type 2

Type 2 Shroud cover has flanged sides over top rails and flanged ends on one end over trough end; other end is plain. This type shroud is used at an inlet opening or next to a hanger at the plain end.

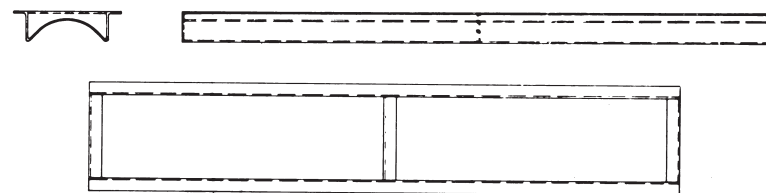

Type 3

Type 3 Shroud cover has flanged sides over top rail and both ends closed and no flanges over ends. This type shroud is used between hangers.

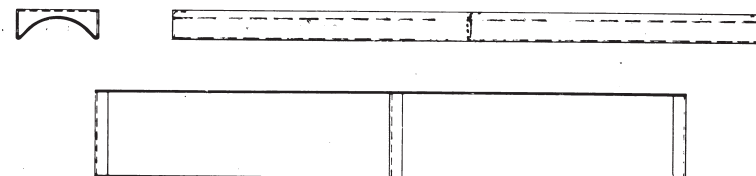

Type 4

Type 4 Shroud cover has no flanges at sides or ends. Bolt holes are provided along sides, for bolting through side of trough. This allows flush mounting with top of trough and a cover may be used over the shroud. This shroud is used mostly for short lengths when installed ahead of an inlet opening.