

Gerber Bucket Elevator OPTIONAL FEATURES

RAPAT
CORPORATION

■ DRIVE OPTIONS-

Many drive options available, contact your Rapat Corporation representative for more information.

■ BACK LEG ROLL OPTION -

For installations that have minimal space for the boot section.

■ SERVICE PLATFORMS -

Provides room for service work on drive and head sections.

■ STEP OFF REST PLATFORMS -

Intermediate platforms placed at pre-specified heights to allow service people to step off ladder to rest when needed.

■ FULLY CAGED LADDERS -

Full ladder enclosures for added safety during routine maintenance and operation.

■ DOWN LEG INLET -

Inlet hopper on down leg side for installations requiring multiple inlets.

■ MULTIPLE BUCKET ROWS -

For larger capacity Bucket Elevators.

■ SEED HANDLING OPTIONS -

Cup spacers and wing tail pulley standard with Seed Handling option.

■ GRAVITY TAKEUP BOOT -

Self cleaning, self adjusting takeup design features a full-floating boot section. (See photo at right).



GRAVITY
TAKEUP
BOOT

GERBER BUCKET ELEVATOR



RAPAT CORPORATION PRODUCT LINE CARD

CONVEYORS

- ENCLOSED BELT
- BAGGING
- CLEATED BELT
- TRUCK & RAILCAR UNLOADERS
- FLEXIBLE SIDEWALL
- PORTABLE BELT
- FOOD HANDLING
- TROUGHING ROLLER
- PLASTIC & WIRE BELTS
- SLIDER BED
- STAINLESS STEEL CONSTRUCTION
- EN-MASSE (DRAG)
- CUSTOM CONVEYORS

DISTRIBUTORS

- ROTO-FLO
- ROTARY VALVE
- SWING FLO

BUCKET ELEVATORS

- COMPLETE BUCKET ELEVATOR ASSEMBLIES
- CUSTOM ACCESSORIES
- BACKLEG ROLL OPTIONS

SCREW CONVEYORS

- TUBE TYPE SCREW CONVEYORS
- AUGER FLIGHTING

HORIZONTAL UNLOAD POWERHEADS

- 25 DEGREE INCLINE POWERHEADS
- BIN UNLOAD TUBES WITH ROLLER SLIDE GATES
- BANJO SUMP BIN UNLOAD TUBES
- ELECTRIC / HYDRAULIC DRIVE KITS

ACCESSORIES

- HOPPER CAR UNLOADERS
- TRANSFER SPOUTING
- CAST IRON TURNHEADS
- REVERSIBLE ELBOWS
- DRAW OFF SPOUTS

INDUSTRIAL MATERIAL HANDLING SOLUTIONS THAT WORK!

At The Rapat Corporation, we approach each project with the intent of finding a better way to solve our customers problems by listening to their individual needs, and applying what we learn to best solve their specific material handling requirements.

Put our experience with some of the largest Fortune 500 Corporations to work for you—call toll-free today for more information.

RAPAT
CORPORATION

The Rapat Corporation ■ Hawley Industrial Park ■ Hawley, MN 56549 USA
Toll Free (800) 325-6377 ■ (218) 483-3344 ■ Fax (218) 483-3535 ■ www.rapat.com

Gerber Bucket Elevator FEATURES

BETTER ENGINEERED FOR OPERATIONAL EFFICIENCY

The Bucket Elevator has been engineered to provide optimal efficiency. Noise, turbulence and materials damage are reduced to lowest possible levels through specialized design and construction. Heavy-duty construction ensures a long life, and competitive pricing offers cost efficiency.

SMOOTH, QUIET CONVEYING

The Bucket Elevator maximizes material handling efficiency with smooth, even fill, minimal material build-up, a generous clearance between trunking and cup for quiet operation, superior pulley design, and easy-access features that simplify maintenance.

All Gerber Bucket Elevator systems are designed and built to exacting specifications—giving you a system that will give you more years of service, with less downtime and repair.

BUCKET DESIGN IS #1

The Bucket Elevator uses buckets that are water-level tested to gauge their *real world* fill capacities, not estimated capacities.

Bucket spacing is optimized for maximum throughput on your bucket elevator. Our engineers review *each* system we build to ensure compatibility with your specific setup. Standard bucket is Maxi-Lift® with other brands available upon request. Additional cup styles are also available upon request.



This means that you will be able to meet or, in most cases, exceed your expected capacity with a Gerber Bucket Elevator.

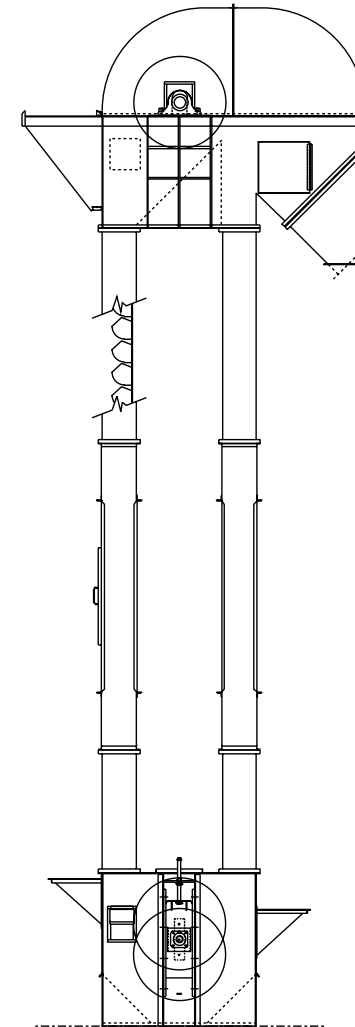
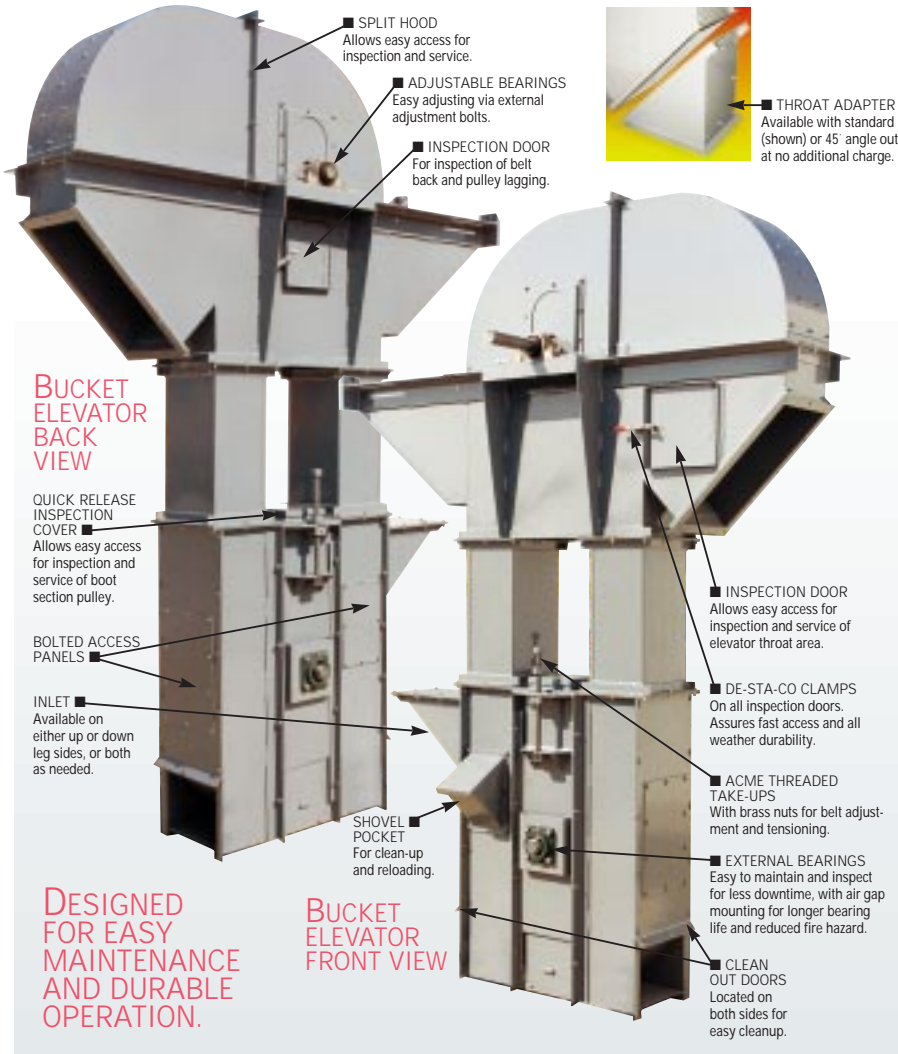

EASY ACCESS FOR MORE REGULAR MAINTENANCE

Most parts requiring regular maintenance are externally mounted for easy access. The drive system, bearings and other parts are all located for fast access.

Internal parts are quickly accessed by removable covers or inspection covers.

BUILT TO HANDLE HIGH-CAPACITY INDUSTRIAL USE

With capacities up to 45,000 bushels per hour, you're assured constant high-capacity operation.

SPECIFICATIONS

Size	Standard models 300 to 45,000 bushels per hour. Higher capacities available upon request.
Belt and Cups	Heavy-duty belt with Maxi-Lift® polyethylene cups. Other belt and cup options available.
Drive	Standard drive system varies with intended use and capacities. We offer Shaft Mounted Gear Reducers, HTD Drive, V Belt Drive as standard. Direct drives optional.
Trunking	Jig built, formed and welded 12 gauge mild steel trunking with optional Stainless Steel or Galvanized steel construction.
Pulleys	Vulcanized rubber lagged, crown-faced head pulley with tapered hubs.
Bearings	Heavy-duty greaseable cast pillow block bearings.
Flanges	Jig welded angle flanges. Tie Braces at all joints.
Lined Throat	AR lined discharge throat assembly.
Outlet	Available with level or 45° angle outlet. (Not shown in photo).
Access Doors	Bolted and hinged access doors.
Boot Section	Heavy-duty Boot Section with built-in shovel pocket.
Head Section	Split hood design for easy access, inspection doors, and bearing jack bolts.

All specifications subject to change without notice.

REPAT
CORPORATION