

FlexWall® Plus for every industry

Why Plus?



The FlexWall Plus is an extension to the FlexWall Classic design "Plus" features that add to its production versatility.

• **MassFlow** – the multi angled, trapezoid shaped polyurethane hopper combined with the angular paddle movement, ensures the flow through the feeder is uniform and fills the screw efficiently.

- **Compact size** – due to the trapezoid shape, the front dimension is narrow, resulting in a compact grouping of 6 feeders around or center collection point (4 ft. diameter)
- **Loss-in-Weight** is the same compact shape, whether the feeder is volumetric or loss-in-weight, its foot print is the same. One unique Mono Block, digi Mass2 or strain gauge scale all fits compactly.

• **External AC Motor** options include:

- Swivel mount for rear screw removal (and twin screw exchange)
- Explosion proof
- Fixed mount for economy

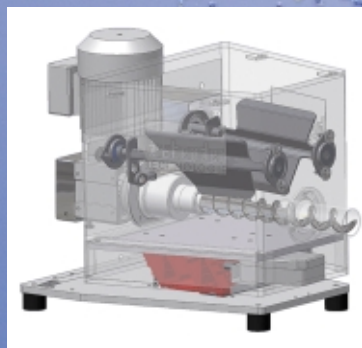

USDA



Pharmaceutical Feeder



Pharmaceutical Construction for Loss-in-Weight and Volumetric

- Totally enclosed
- Totally sealed
- Polished 316SS
- Clean in place spray ball
- EX proof
- Sanitary clamp connection

Sanitary Feeder



- Built to 3A Dairy Standards Inc.
- Spec for Auger Type Feeders NO#81-00
- Inspected and Accepted by USDA Dairy Grading Branch

Easy Change



- Hopper/Screw/Tube/Pigment Lift-Off
- Stores on Flat Base for Re-Use
- Another Hopper/Screw/Tube Lifted-In
- Feeder Base/Motor/Paddles Remain
- Disconnect by 2 Clamps
- Motor Coupling Self Release

Twin-Screw Changeover



- Twin Screw/Single Screw Interchangeable
- Feeder Versatility - Powders, Pellets, Flakes, Fibers
- Motor on Swing Bracket
- Screw Removes from Rear
- 20mm/40mm Twin Screws

www.brabenderti.com

Toll Free: (888) 284-4574 • Fax: (905) 670-2557 • E-mail: sales@brabenderti.com



FlexWall® Plus Advantages

CONVENIENT • REPEATABLE • RELIABLE

Easy to Operate Reliably, Easy to Access

- Carousel comprises 6 feeders with a central discharge
- Carousel diameter with FW40=4 ft, FW80=7ft
- Screws easily removed from rear of feeder
- Feeders are retractable on sliding base
- Self releasing sealed process connection
- Direct mounted scale using Digi MASS 2 load cell



The FlexWall® Plus Design compact, accessible, easy to maintain

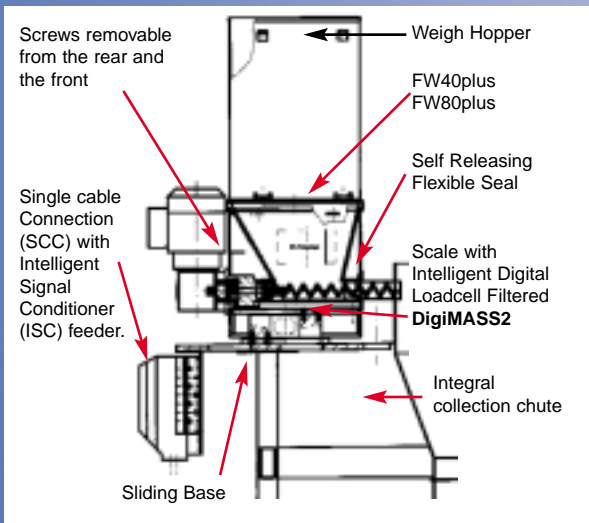

The FlexWall® Plus Performance

Two models are available; FW40 (max. screw dia 1.6 ins.) and FW80 (max.screw dia 3.2 ins.) that deliver feed rates from 0.5 to 180 cu. ft per hour. The AC motors are speed controlled from a commercially available Variable Frequency Drive (VFD).

Loss-in-Weight Version

A Brabender Monoblock with DigiMass 2 loadcell is added and combined with either a Congrav® microcomputer controller or an intelligent Signal Conditioner (ISC).

The ISC are feeder-mounted Brabender feed rate control modules that allow the feeder to be integrated to the Brabender Field Bus System. This combination delivers a fully digital high-tech loss-in-weight feeder which performs reliably and accurately in the most challenging environments.

