

Brabender Technologie

SiloTray Feeder

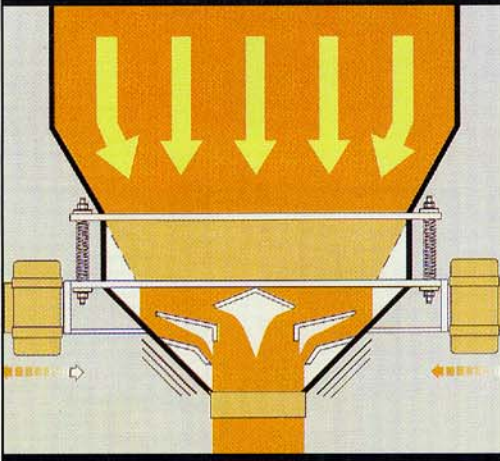

SILOTRAY FEEDER

The Brabender SiloTray Feeder is a vibratory discharge and proportioning device which is suspended from the bottom of silos and bins. Special hanger arms center the unit and allow horizontal vibration.

Unbalanced AC motors apply motion to the unit and control the discharge rate. For volumetric feeding applications a VDF is provided to vary the frequency of vibration. Amplitude is adjustable.

The operation method is independent from agitators and prevents compaction and ensures "first-in, first-out" discharge without bridging or particle deterioration.

Feed rates are repeatable, the unit is perfectly suited to feeding in pneumatic or mechanical conveying systems. Typical applications include:

- accurate controlled feed rate directly beneath a storage hopper;
- as the feed device for a loss-in-weight feeder;
- as a refill device for a loss-in-weight feeder where a controlled rate refill is required.

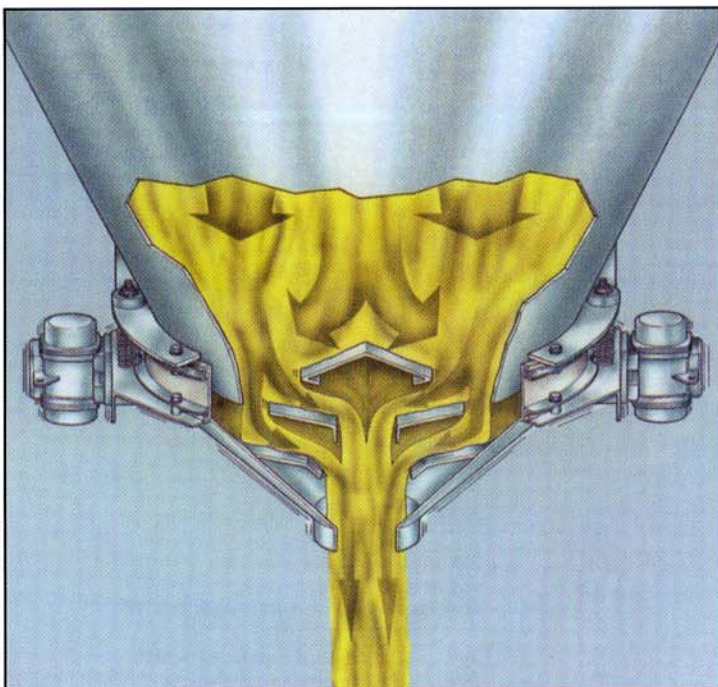

CAPACITY TABLE

Model	Diameter ins.	Max. Feed Rate cu.ft/hr.
ST450	18	3.6
ST1200	48	3600

Brabender SiloTray Feeder

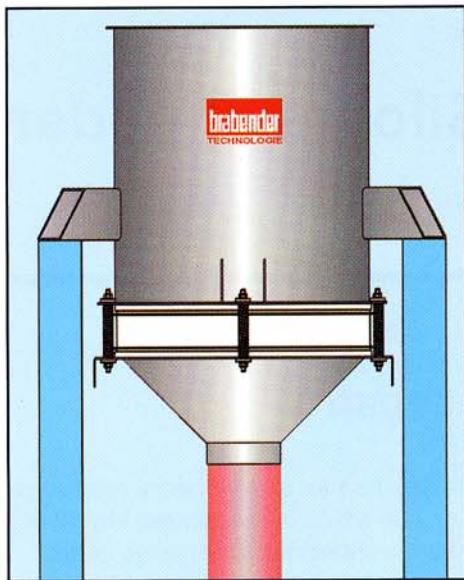

Controlled discharge at a specified rate.

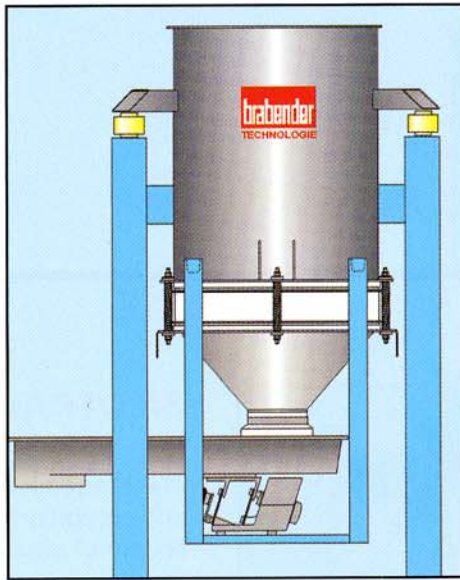

Gravimetric feeding using a vibrating tray discharge feeder.

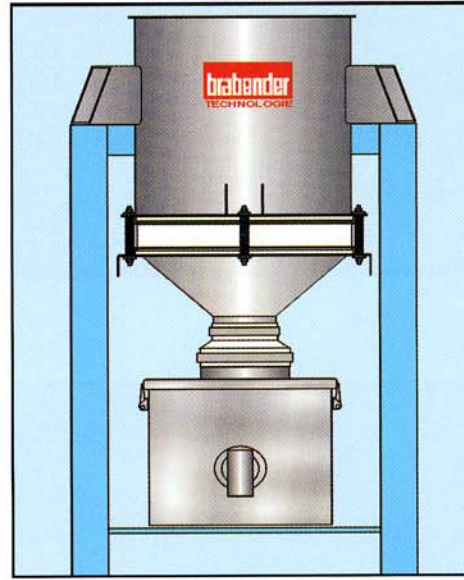

Volumetric feeding using a FlexWall™ discharge feeder.

FIELDS OF APPLICATION

- Continuous volumetric feeding or controlled discharge at a specified adjustable discharge rate.
- Continuous gravimetric loss-in-weight feeding in conjunction with a scale system.
- Loss-in-weight batching in conjunction with a scale system.
- Gain-in-weight batching in conjunction with a weighed collecting hopper.

FEEDABLE BULK MATERIALS

The Brabender SiloTray feeder is suitable for all flowable bulk materials with the exception of ingredients with hygroscopic, sticky or floodable characteristics.

- Granules.
- Powders.
- Flakes.
- Fibrous materials and chips eg: glass fibers and film chips.

Leading Manufacturer of Feeding, Weighing and Discharging Equipment
with Over 50 Representative and Service Centers Worldwide

Headquarters:

Brabender Technologie KG
Kulturstrasse 55-73
D-47055 Duisburg, Germany

Tel: ++49 (0) 203-99 84-0
Fax: ++49 (0) 203-99 84-155
Web: www.brabender-technologie.com



North American Headquarters:

Brabender Technologie Inc.
6500 Kestrel Road
Mississauga, Ontario, Canada L5T 1Z6

Tel: (888) 284-4574 (905) 670-2933
Fax: (905) 670-2557
Web: www.brabenderti.com