



SCOTT

Industrial Batch Mixers



SCOTT



BUILT FOR TODAY
TO LAST FOR TOMORROW

SCOTT EQUIPMENT COMPANY

605 4th Avenue N.W.
New Prague, Minnesota 56071
1.800.394.2591 • 952.758.2591 • Fax: 952.758.4377
E-Mail: sales@scottequipment.com
Website: <http://www.scottequipment.com>

Scott Mixers... Only our best ingredients to mix yours.

Durably constructed in either mild or stainless steel, Scott mixers insure accurate mixing of all types of products from fine powdered materials to coarse ground ingredients. All Scott industrial mixers are custom built to efficiently and cost-effectively meet each application requirement. Our engineering department continually remains on the cutting edge of technology and design. For over 33 years, Scott Equipment has been dedicated to produce quality products for a diverse group of industries.

Whatever your mixing needs, Scott has the solution.

Scott Industrial Batch Mixers



FEATURES

- ◆ Custom manufactured in mild or stainless steel.
- ◆ Sanitary finishes available up to and including 3A Dairy Standard.
- ◆ Complete mix cycles of less than four minutes.

Stainless Steel

- ◆ Available in 1 to 1,500 cubic foot capacities.
- ◆ Ribbon, paddle or paddle/ribbon combination design in mild or stainless steel with a variety of dischargers available.
- ◆ Scott Mixers are constructed with heavy-plate tub bottom and end plates. A variety of drive assembly designs are available including shaft mount, gear head or direct drive. All drive assemblies are at least AGMA Class II rating.

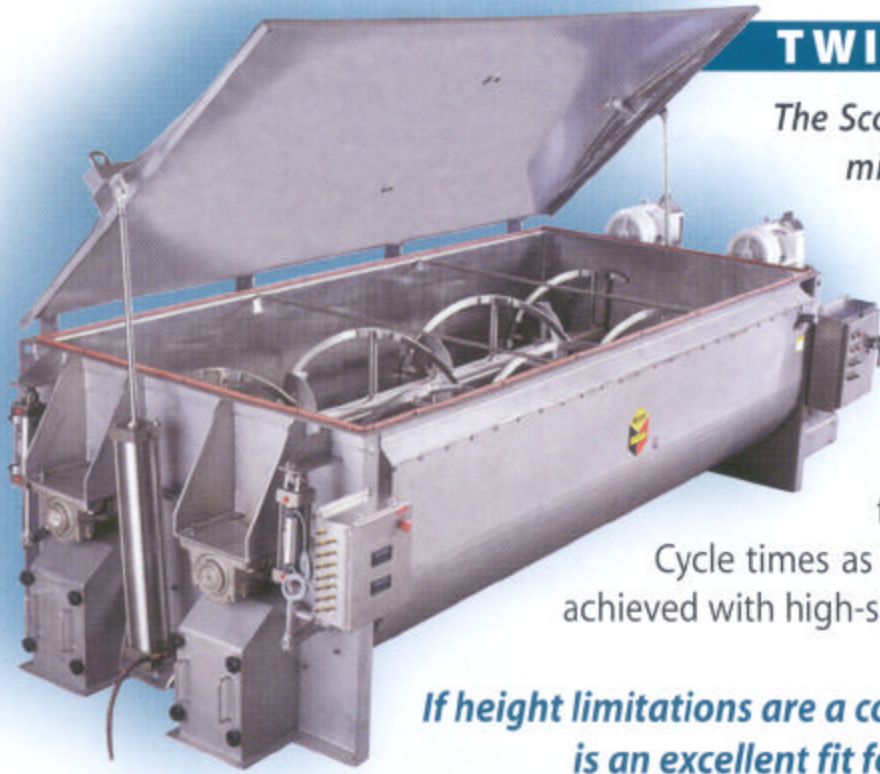

TWIN SHAFT MIXER

The Scott Twin Shaft Mixer is ideal for mixing various materials in a balanced action to achieve a homogenous product. The combination of paddles and ribbon flighting mounted on the twin agitator design offers unsurpassed mixing efficiency for a wide variety of products.

Cycle times as low as 1 to 1½ minutes can be achieved with high-speed scale designs.

If height limitations are a concern, the Twin Shaft Mixer is an excellent fit for restricted areas.

JACKETED MIXER

Jacketed mixers are ideal in applications where heating or cooling the product is desired.

The fluidization created by the mixing action offers the products excellent surface area coverage on the mixer cylinder.

This action greatly increases the efficiency of the unit to act as a drying or cooling vessel. These mixers are available in mild or stainless steel and are manufactured in a complete sanitary design with steam heat, hot water heat or cold water jackets for cooling.

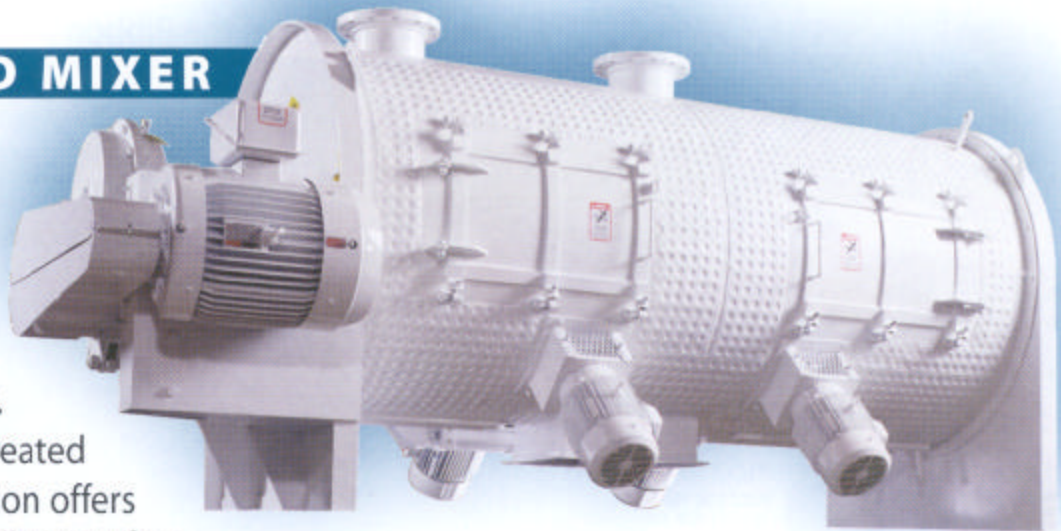

Scott Quality...

Scott durability that companies have come to rely on.

DISCHARGE GATES

Scott Equipment offers a variety of discharge gates, which are available in sizes ranging from 2" in diameter to 36" in diameter. With the ribbon agitator design, the discharge gate can be located on either end or in the center of the mixer. The paddle agitator design must have the discharge located in the center of the mixer for efficient cleanout. The selection

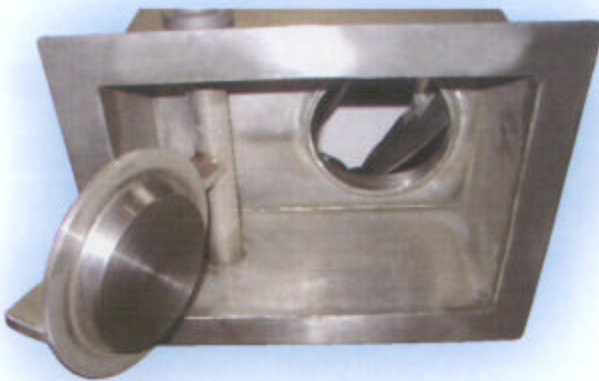
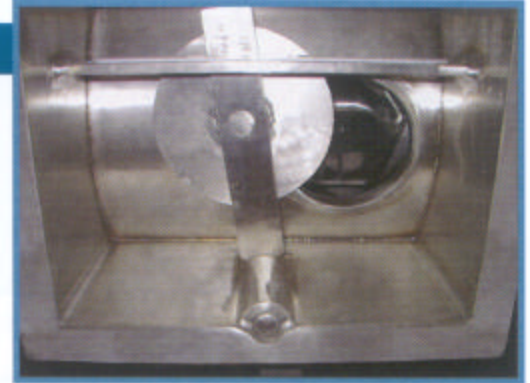

of discharge gates available from Scott Equipment Company will suit your needs and for unique applications, custom designed discharges are available.

- ◆ Hinged Drop Gate
- ◆ Hinged Plug Gate
- ◆ Pipe Flange Adapter
- ◆ Pivot Gate
- ◆ Sanitary Knife Gate

STANDARD SEALS

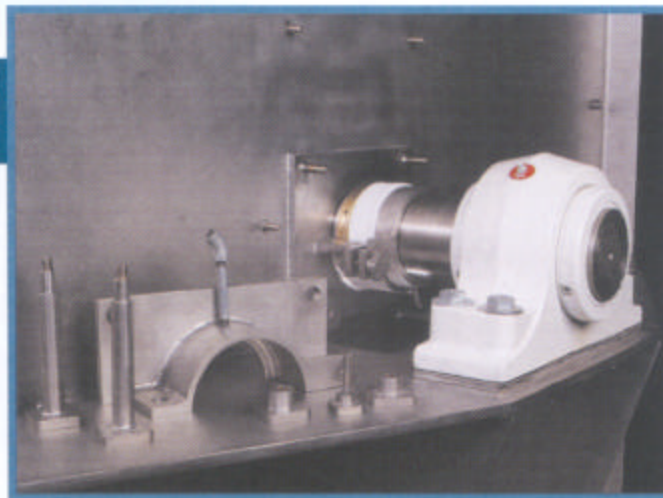

For most mixing applications, Scott's standard seals are suitable for the Horizontal Mixer. These seals will meet most requirements for today's mixing industry, however if you have a particular concern with your product, Scott will accommodate your needs by designing a custom seal.

- ◆ Ultra Sanitary Seal
 - USDA 3A Dairy standard seal
 - No tools required for disassembly
 - All flanges split to remove for washing
- ◆ Split Packing Gland Seal
 - Graphite or nylon packing
- ◆ Air Purge Seal
 - Air purge packing gland seals are available for special applications
 - Air purge seals prevent leakage of fine materials
- ◆ Packing Gland Seal
 - 3 or more rings of packing available

WEBSITE...<http://www.scottequipment.com>

RIBBON AGITATOR DESIGN

- ▣ Scott's sanitary design ribbons are constructed of a stainless steel close-wrapped balanced design.
- ▣ Triple-mixing action insures a smoother, more efficient blending of the ingredients.
- ▣ Polished sanitary design helps eliminate cross contamination between mixing runs.
- ▣ Optional air-purge design through the main shaft provides complete cleanout.

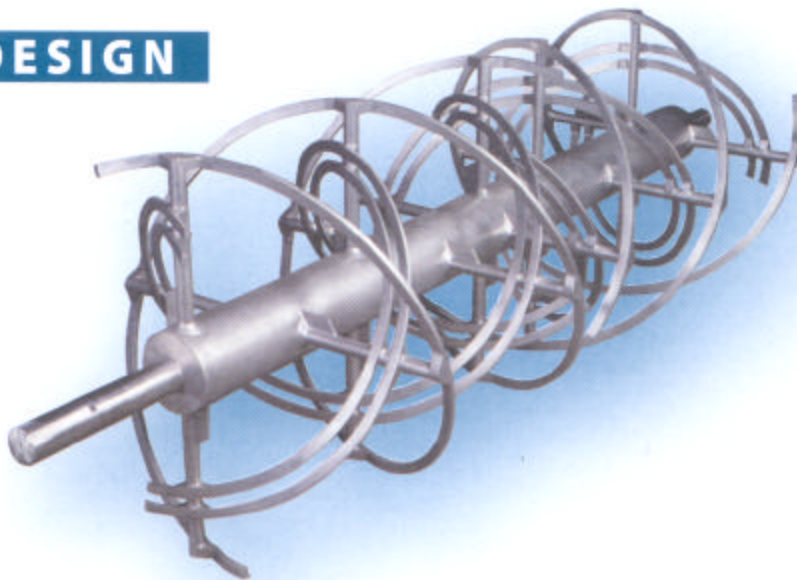

RIBBON/PADDLE AGITATOR DESIGN

- ▣ Combines the benefits of the Paddle Agitator Design while simultaneously giving end-to-end mixing action of the Ribbon Mixer.

PADDLE AGITATOR DESIGN

- ▣ Paddle design allows for easy cleaning of agitator assembly.
- ▣ Available in polished sanitary design up to 3A Dairy Standard.
- ▣ Paddle blades are adjustable and replaceable to maintain close tolerance to the mixer bottom in non-sanitary models.



SCOTT EQUIPMENT COMPANY

605 4th Avenue N.W.

New Prague, Minnesota 56071

(800)394-2591 (952)758-2591 Fax: (952)758-4377

E-Mail: sales@scottequipment.com

Website: <http://www.scottequipment.com>

CALL TOLL FREE... 1.800.394.2591

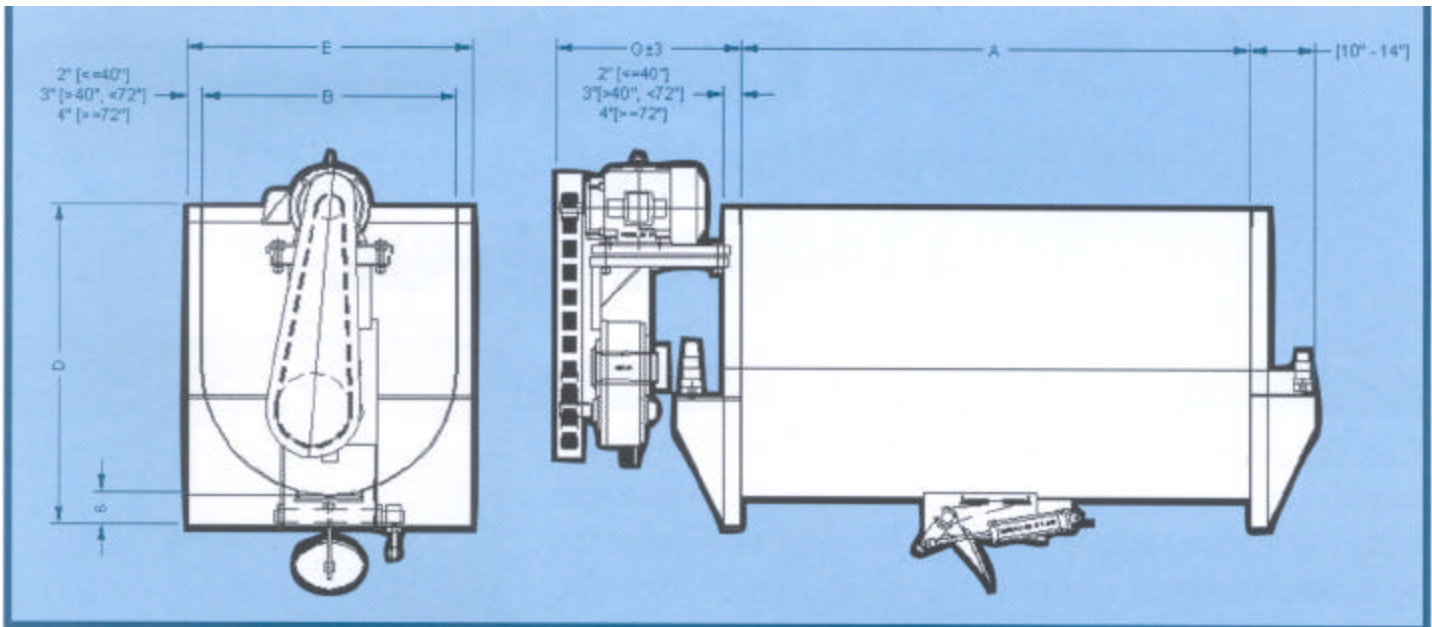

Model	Size	Mixer Capacity		A		B		D		E		G	
		CuBt Ft.	CuBt M	in	mm	in	mm	in	mm	in	mm	in	mm
18" Mixers													
HM1818	18" X 18"	2.6	0.1	18	457	18	457	28	711	22	559	23	584
HM182	18" X 24"	3.5	0.1	24	610	18	457	28	711	22	559	23	584
HM183	18" X 36"	5.0	0.1	36	914	18	457	28	711	22	559	23	584
24" Mixers													
HM243	24" X 36"	10	0.3	36	914	24	610	34	864	28	711	23	584
30" Mixers													
HM304	30" X 48"	20	0.6	48	1219	30	762	40	1016	34	864	23	584
36" Mixers													
HM364	36" X 48"	28	0.8	48	1219	36	914	46	1168	40	1016	23	584
40" Mixers													
HM404	40" X 48"	35	1.0	60	1524	48	1219	50	1270	54	1372	23	584
HM405	40" X 60"	44	1.2	72	1829	48	1219	50	1270	54	1372	23	584
44" Mixers													
HM455	44" X 60"	53	1.5	60	1524	44	1118	56	1422	50	1270	23	584
48" Mixers													
HM485	48" X 60"	62	1.8	60	1524	48	1219	60	1524	54	1372	25	635
HM486	48" X 72"	74	2.1	72	1829	48	1219	60	1524	54	1372	25	635
HM488	48" X 96"	100	2.8	96	2438	48	1219	60	1524	54	1372	28	711
HM489	48" X 108"	112	3.2	108	2743	48	1219	60	1524	54	1372	28	711
HM4810	48" X 120"	125	3.5	120	3048	48	1219	60	1524	54	1372	30	762
HM4812	48" X 144"	150	4.2	144	3658	48	1219	60	1524	54	1372	30	762
54" Mixers													
HM548	54" X 96"	126	3.6	96	2438	54	1372	66	1678	60	1524	30	762
HM5410	54" X 120"	158	4.5	120	3048	54	1372	66	1678	60	1524	30	762
HM5412	54" X 144"	190	5.4	144	3658	54	1372	66	1678	60	1524	30	762
60" Mixers													
HM6010	60" X 120"	195	5.5	120	3048	60	1524	72	1829	66	1678	34	864
HM6012	60" X 144"	235	6.7	144	3658	60	1524	72	1829	66	1678	34	864
66" Mixers													
HM6611	66" X 132"	260	7.4	132	3353	66	1678	78	1981	72	1829	34	864
HM6612	66" X 144"	284	8.0	144	3658	66	1678	78	1981	72	1829	34	864
HM6615	66" X 180"	530	9.9	180	4572	66	1678	78	1981	72	1829	34	864
72" Mixers													
HMA7212	72" X 144"	338	9.6	144	3658	72	1829	86	2184	80	2032	36	914
HMA7213	72" X 156"	367	10.4	156	3962	72	1829	86	2184	80	2032	36	914
HMA7214	72" X 168"	395	11.2	168	4267	72	1829	86	2184	80	2032	36	914
78" Mixers													
HM7813	78" X 156"	430	12.2	156	3962	78	1981	92	2337	86	2184	36	914
HM7814	78" X 168"	465	13.2	168	4267	78	1981	92	2337	86	2184	36	914
HM7815	78" X 180"	497	14.1	180	4572	78	1981	92	2337	86	2184	36	914
84" Mixers													
HM8414	84" X 168"	538	15.2	168	4267	84	2134	98	2489	92	2337	38	965
HM8415	84" X 180"	577	16.3	180	4572	84	2134	98	2489	92	2337	38	965
HM8416	84" X 192"	615	17.4	192	4877	84	2134	98	2489	92	2337	38	965
96" Mixers													
HM9616	96" X 192"	803	22.7	192	4877	96	2438	110	2794	104	2642	40	1016
HM9617	96" X 204"	854	24.2	204	5182	96	2438	110	2794	104	2642	40	1016
HM9618	96" X 216"	904	25.6	216	5486	96	2438	110	2794	104	2642	40	1016



Other Quality Products from

SCOTT
EQUIPMENT COMPANY

- AST Dryer™
- ASM Fine Grinder
- Cooler
- Dominator Crusher
- High Speed Turbo Blender
- Horizontal Paddle Mixer
- Horizontal Ribbon Mixer
- Particulate Capture Unit
- Pellet Mill Conditioner
- Plow Mixer
- Pugmill
- Rotary Drum Mixer
- Shredderizer
- Storage Bins
- Tender Blend Mixer
- Turbo Separator
- Turbo Grinder
- Twin Shaft Mixer

Services

- Testing Facilities
- Equipment Rental Program
- On-Site Repair Service