

SCOTT

Dominator Crusher

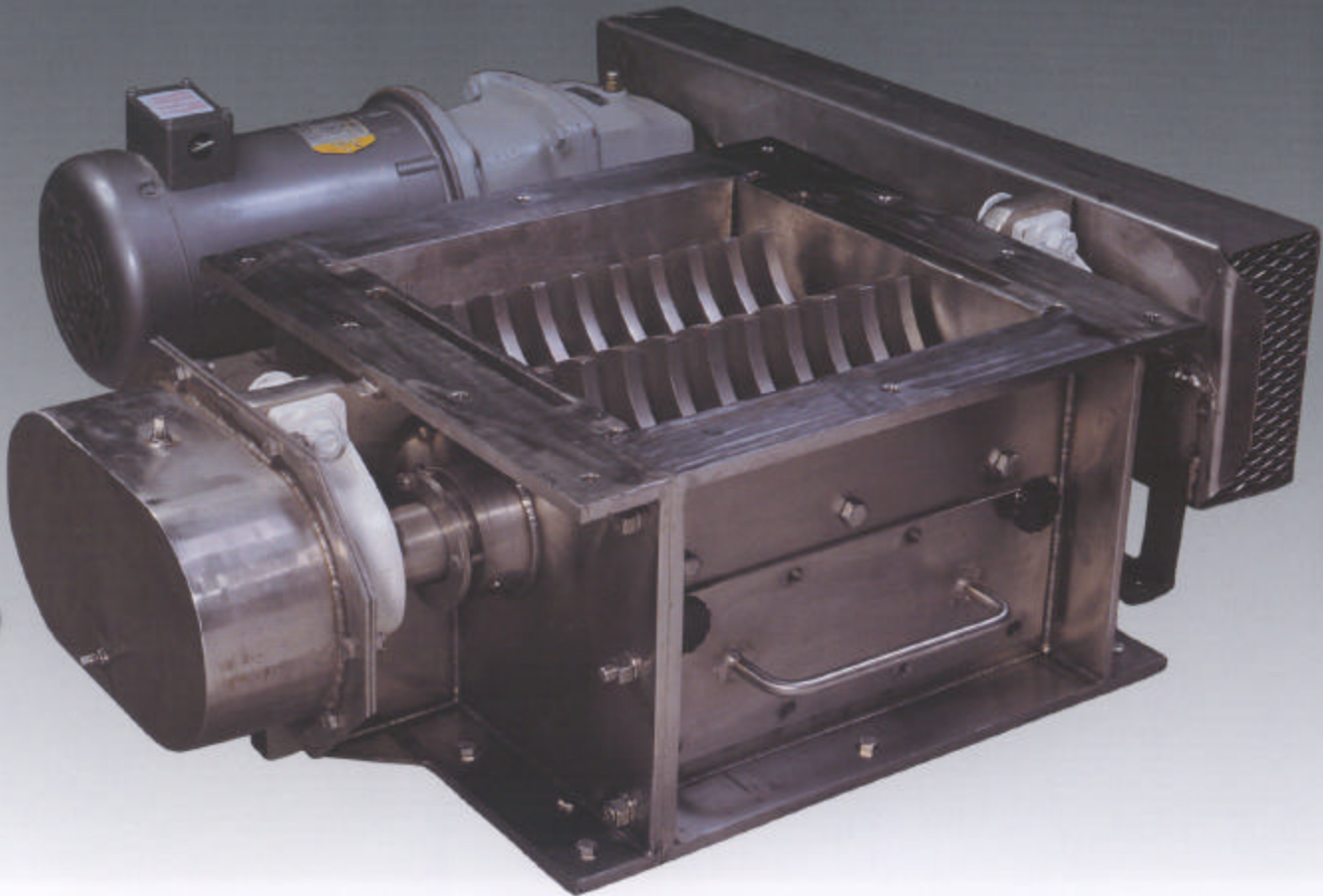

Scott designs and manufactures a superior size reduction machine, the Dominator Crusher. This equipment breaks up and crushes a variety of materials including bones, chemicals, food, salt, and fertilizer. The Crusher also delumps virtually all agglomerations and chunks.

The Dominator Crusher has six different tooth configurations, a unique feature which makes it more efficient. This unparalleled design allows a greater variety of products to be broken up.

Because the teeth can be moved close together or far apart, a wide range of materials can be crushed and different end-product sizes can be achieved.

Our Crusher is available in carbon steel, stainless steel, standard, and special food grade finishes. It ranges from 9"x9" to 48"x48" to accommodate your changing needs and can be operated with or without a sizing screen.

We're Notorious For Durability.

We've established durability in mixers, blenders, bulk material bins, and now size reduction equipment. Our company has been perfecting products in this industry for over twenty-five years with special emphasis on quality workmanship. Because of this, our implements are notorious for low maintenance and consistent performance.

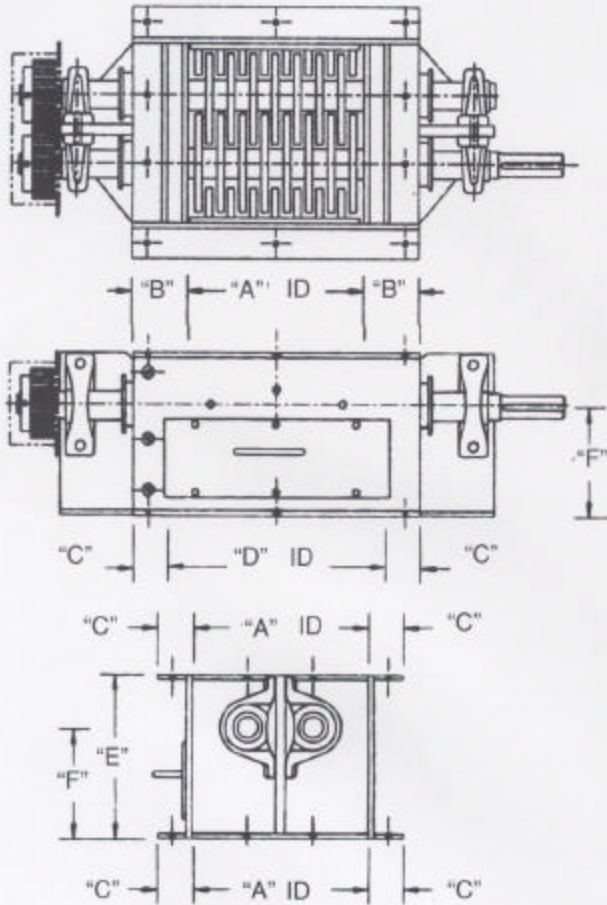

SPECIFICATION

Machine	Size	A	B	C	D	E	F
CR12-12	12 X 12	12	3 3/4	2 3/8	14 3/4	11	7 1/2
CR15-15	15 X 15	15	3 7/8	2 7/8	17	12	7 3/4
CR 18-18	18 X 18	18	3 7/8	2 7/8	20	14	9 1/4
CR 24-24	24 X 24	24	3 1/2	2 1/2	26	18	11
CR 36-36	36 X 36	36	4 3/4	3 1/8	39 1/4	25	15
CR 48-48	48 X 48	48	6	4 1/2	51	36	21 1/2



Crusher, Feeder and Stand

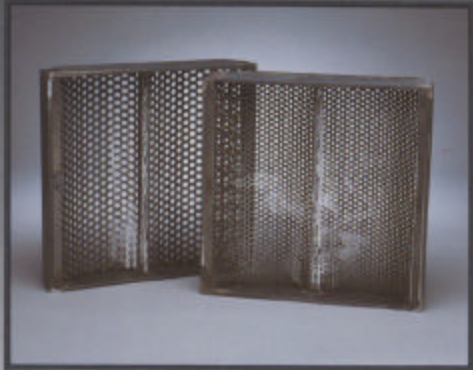

Screens



Rotor Shafts



Call toll free 1-800-264-9519

After all, you wouldn't want to mix us up with anyone else.



SCOTT
EQUIPMENT COMPANY

605 Fourth Avenue Northwest
New Prague, MN 56071

952-758-2591
Fax: 952-758-4377