

# Weigh Belt Feeders

## DBW-G1-350 Model Specifications



The Brabender Weigh-Belt Feeder DBW-G1-350 is a speed-controlled gravimetric feeding unit designed to feed normal to well flowing ingredients. High accuracy, stable design and compact dimensions even in case of high feed rates distinguish this feeder. The G1-350 can be used for continuous feeding applications, for batching and as a measuring belt feeder for continuous through-put measurement.

The weigh-belt feeder consists of a stable stainless steel casing and a built-in torsion-free cantilever belt frame with integrated weighing system.

Full accessibility due to removable cover plates ensures easy cleaning and maintenance. The belt can be taken off from the side for easy replacement.

For special cleaning requirements an easy clean version is offered with a slide-out belt frame, and a sanitary version for wet cleaning is available. When ingredients are poorly flowing or floodable, the Brabender Weigh-Belt Feeder can be combined with a controlled pre-feeder.

The exterior feeder casing and all parts in contact with the ingredient are made of stainless steel 1.4301 (304 SS).

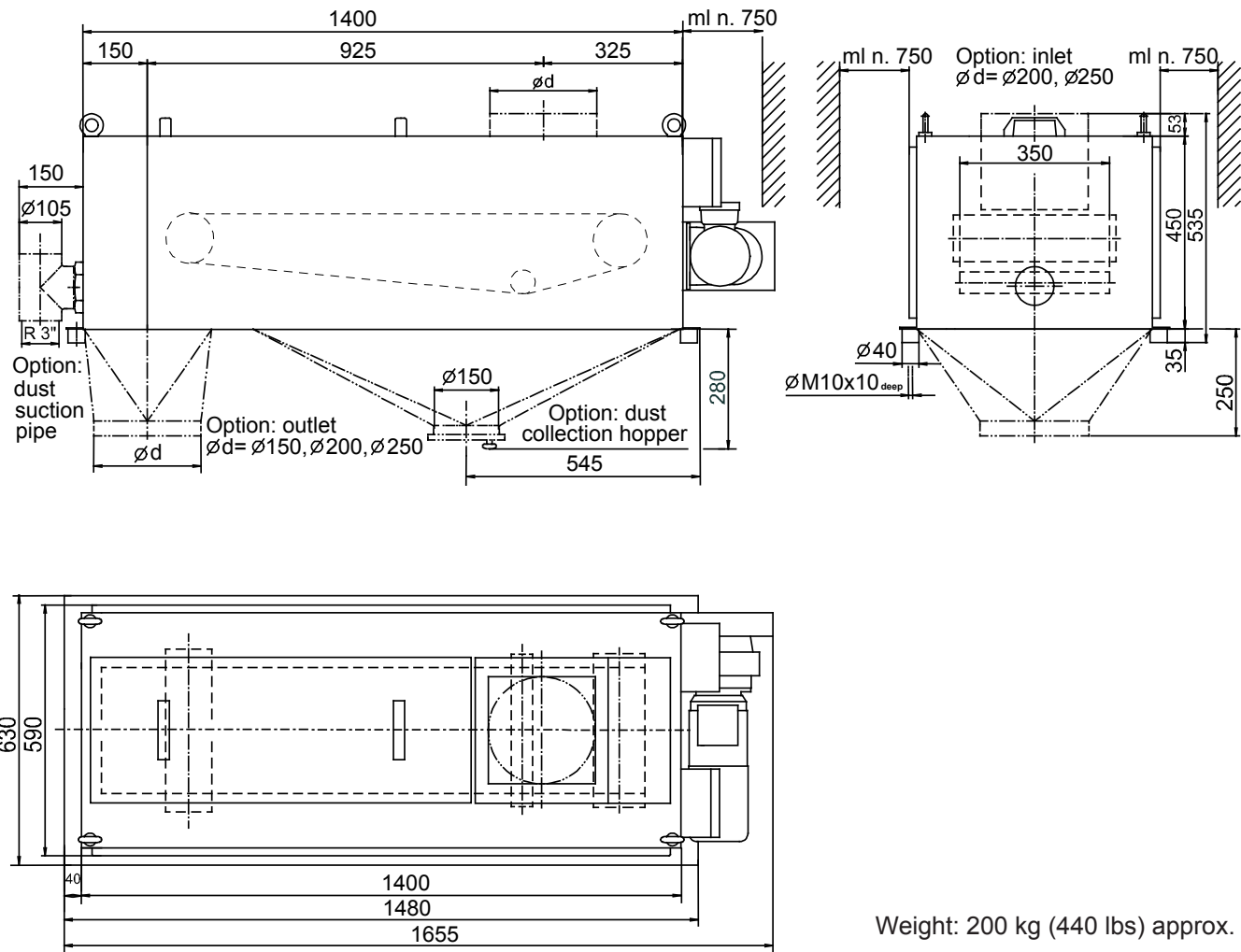
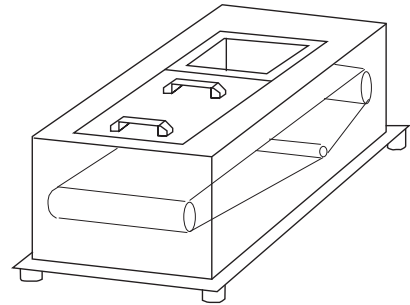

Weight: 200 kg (440 lbs) approx.

## Technical Data

### Feed Rate Range

60-34,000 lbs/hr (27-1,550 kg/hr) or  
1.2-850 cuft/hr (0.03-24 m<sup>3</sup>/hr)  
(Load Cell Limit: 21,800 lbs/hr)  
Turndown ratio: 1:10 (1:100  
with mechanical layer height  
adjustment).  
Gate Height: 0-4 in (0-100 mm)

### Accuracy

**Repeatability:** ± 1% based on 30  
consecutive samples of 1 minute,  
1 pound, or one belt revolution,  
whichever is largest

### Weighing System

Load cell: strain gauge.  
Protection: IP 65 (fully  
enclosed).  
Rated load: 5 kg. (11 lbs.)  
Mech. overload protection: 20 kg  
(44 lbs).  
Operating temperature: -30°C to  
+70°C (-22°F to +158°F).

### Belt

Belt Speed: 0.8-90 ft/s (0.2-27 m/s)  
Belt Width: 14 in (350 mm)  
Coating: Urethane (food-proof).  
Carcass: endlessly woven  
polyester fabric.  
Operating temperature: -30°C to  
+100°C (-22°F to +212°F).

### Belt Drive

A.C. gear motor with integrated  
tachometer generator:  
Wattage: 1/2 HP (0.37 KW)  
Voltage: 230/460 V.  
Current: 3.2/0.44 A.  
Protection: IP 55.  
Insulation class: F

### Options

Round inlet, Dia. 200 or 250 mm.  
Round outlet, Dia. 50, 200, 250, 300  
mm  
Flexible inlet and outlet sleeves  
(neoprene).  
Inlet shut-off valve.  
Calibration valve.  
Dust suction pipe (outlet side).  
Dust collection hopper.  
Storage hopper 100 L.  
Belt movement monitoring system  
(speed sensor on idle roller).  
Pressure-tight design.  
Explosion-proof design.  
Pre-feeders.  
Special belt materials (silicone,  
nitrile, etc.).  
Easy clean design with belt frame  
extractable to the side.

#### Sanitary version:

- full stainless steel 1.4301 (304 SS).
- drive motor IP 65 (fully enclosed).
- rounded corners.
- extractable belt frame.
- washdown-proof.

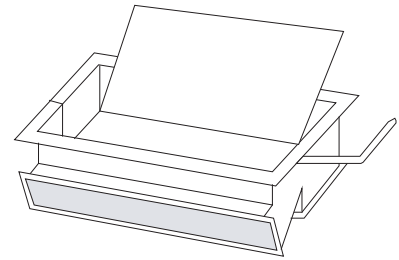

Calibration valve

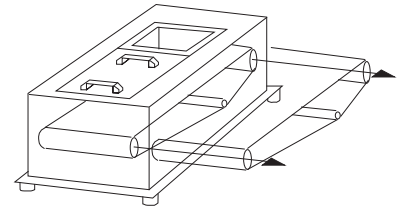

Easy clean design

### Feed Controller

Microcomputer Congrav for single  
or multi-feeder installations: see  
relevant Brabender 7000 series  
documents.

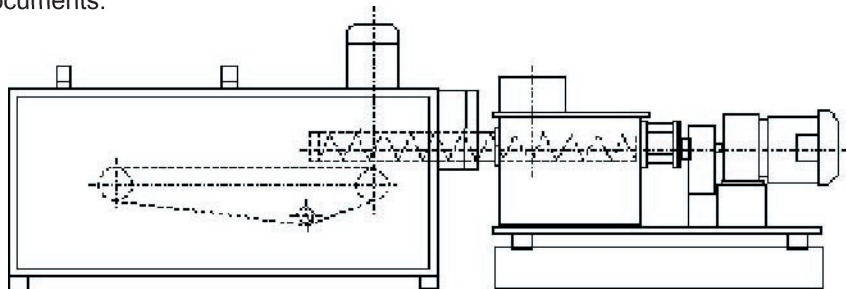

Weigh-belt feeder with pre-feeder



**Head Office:**  
6500 Kestrel Road  
Mississauga, Ontario  
Canada, L5T 1Z6

Telephone: (905) 670-2933  
Toll Free: (888) 284-4574  
Facsimile: (905) 670-2557  
Email: sales@brabenderti.com